

## Measurement 4

# MEASUREMENT OF THE CHARACTERISTICS OF A FLOW-THROUGH WATER HEATER

## 1. Aim of the measurement

The aim of this measurement is to measure the characteristic curves of a flow-through water heater, namely:

- the temperature of the outflowing water as the function of time, starting from the time when the apparatus is turned on (the heat-up curve),
- the steady-state temperature of the outflowing water as the function of the mass flow rate.

## 2. Theory

This section covers the theoretical knowledge necessary to understand this measurement. First, we define the total enthalpy, and examine the meaning of each term in the formula defining it. Moreover, the relationship of these terms with the power of hydraulic or thermal machines is covered. Finally, the most common temperature measurement instruments are introduced.

### 2.1 Total enthalpy

The total enthalpy is an important quantity in the theory of machines in which there is some sort of fluid flow. The two great branches of these type of machines are the **hydraulic machines** (pumps, fans, tec.), and **thermal machines** (combustion engine, gas turbine, etc.).

The **total enthalpy** is defined the following way:

$$i_t = \frac{p}{\rho} + gh + \frac{v^2}{2} + u \left( \frac{J}{kg} \right), \quad 1$$

in which the terms of the summation are the

- work of the external pressure on the fluid,  $\left( \frac{p}{\rho} \right)$ ,
- potential energy of the fluid,  $(gh)$ ,
- kinetic energy of the fluid,  $\left( \frac{v^2}{2} \right)$ ,
- internal energy of the fluid,  $(u)$ .

The **total enthalpy** is constant in a fluid flow, if the thermal energy exchange between the fluid and the external environment is negligible. However, machines are based on changing this quantity like in the present experiment.

The internal energy ( $u$ ) stems from the molecular structure of the material, and includes the translational motion, rotation and vibration of the molecules. The internal energy can be described by the **thermal state** of the material. The change in the internal energy of ideal gases and liquids, considering constant volume during the process, is proportional to the change in the temperature. The internal energy is a relative quantity similarly to the potential energy, meaning that its value can only be given relative to a reference state, and its absolute value is unknown. Therefore, the internal energy cannot be measured directly, only its change can be observed. The specific internal energy is the internal energy per unit mass, denoted by  $u$  with the unit of J/kg.

Excluding the **internal energy** from the **total enthalpy** of the fluid, the remaining quantity is called the **Bernoulli-enthalpy** ( $i_B$ ) of the system, which is known to you from the Bernoulli equation

$$i_B = \frac{p}{\rho} + gh + \frac{v^2}{2} \left( \frac{J}{kg} \right), \quad (2)$$

In an ideal fluid, this sum (calculated on a streamline) is **constant**.

## 2.2 Calculation of the power

There are two cases from the perspective of total enthalpy change:

- a) we want to decrease the total enthalpy of the fluid, to provide energy or work,
- b) we want to increase the total enthalpy of the fluid, e.g. heat it up, speed it up. This can be done by performing work on the fluid, i.e. transferring energy to it.

In turbomachinery, from the change of total enthalpy ( $\Delta i_t$ ) and the mass flow rate ( $\dot{m}$ ), the **power** ( $P$ ) can be calculated:

$$P = \dot{m} \Delta i_t \left( \frac{kg}{s} \cdot \frac{J}{kg} = \frac{J}{s} = W \right). \quad (3)$$

This power can either be positive or negative, depending on whether energy is *supplied to* or *drawn from* the machine.

In the case of constant-density fluids, the **mass flow rate** can be calculated from the volumetric flow rate (e.g. litres/min or m<sup>3</sup>/s), which can be measured easily. Knowing the density of the fluid ( $\rho$ ), the mass flow rate is the following:

$$\dot{m} = \rho q \left( \frac{kg}{m^3} \cdot \frac{m^3}{s} = \frac{kg}{s} \right). \quad (4)$$

According to equation (1), any change in the **total enthalpy** ( $\Delta i_t$ ) can be due to the four different terms. In real-life cases, generally some of these terms can be neglected as they do not change significantly. Here is a brief list of the most general simplifications in mechanical engineering.

- a) When dealing with **liquids** (incompressible fluids), whether energy is given to the fluid (pumps), or energy is taken from it (water turbines), the change in the temperature is negligible, so the change of the internal energy is approximately zero. In these cases, only the change of the **Bernoulli-enthalpy** has to be tracked, i.e. the pressures (p), velocities (v) and heights (h) have to be measured.
- b) In the case of **gaseous** fluids (gas, steam, etc.), due to the small density of the fluid, the **potential energy** can be almost always **neglected**. This means that the terms of the sum

$$i_{st} = \frac{p}{\rho} + \frac{v^2}{2} + u \left( \frac{J}{kg} \right), \quad (5)$$

have to be calculated to quantify the total enthalpy change of the fluid. This quantity is called the **stagnation point enthalpy** and it is used in high speed gas flows with heat transfer. For this, the pressures (p), velocities (v) and temperatures (t) have to be measured.

- c) Considering processes in which the change of the energy of the fluid is dominated by **heat transfer** or if the flow velocity is low, the term  $\frac{v^2}{2}$  in equation (5) is small compared to the other two terms. The sum of these two terms is simply called **thermodynamic enthalpy**:

$$i = \frac{p}{\rho} + u \left( \frac{J}{kg} \right). \quad (6)$$

In order to obtain this quantity, the pressures (p) and temperatures (t) need to be measured.

- d) The energy of a **gaseous fluid** can often change in a manner that the density change is relatively small, and the **temperature change** of the fluid is **negligible**. In this case the **change of the kinetic energy** cannot be ignored. Based on this, the energy change in the case of wind turbines (where the kinetic energy of the air is converted to mechanical energy), or fans (which increases the enthalpy of the fluid),

$$p_t = p + \frac{\rho}{2} v^2 \left( \frac{J}{m^3} \right). \quad (7)$$

For reasons of tradition here energy per **unit volume** is used, which is called **total pressure**.

### 2.3. Temperature measurement

Many methods have been developed for measuring temperatures. Most of these rely on measuring some physical property of a specific material that changes with the temperature. A few common types of temperature measurement instruments are the following:

- a) **Glass thermometers**: industrial glass thermometers are straightforward, widely used instruments. The measurement is based on the difference between the heat expansion

coefficient of the glass body of the device and the liquid inside it. The instrument consists of a small glass chamber followed by a capillary tube closed at its end. The glass chamber is filled with liquid, and if the temperature increases, so does the volume of the liquid and it rises in the tube. A decrease in the temperature results in a reduced liquid volume and the liquid flows back to the chamber. The temperature can be read from the temperature scale behind/next to the tube.

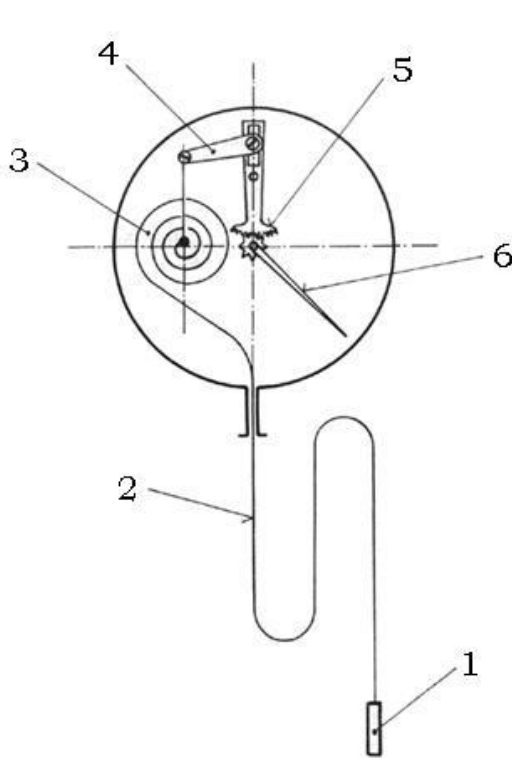

Figure 4.1. Manometric thermometer

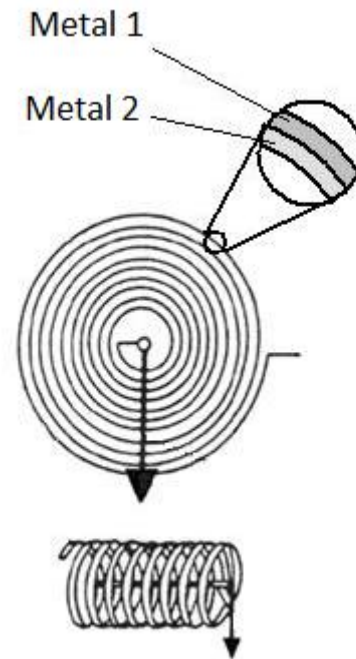

Figure 4.2. Bimetallic temperature gauge

- b) **Manometric thermometer:** in this type of instrument the measurement of temperature is based on the pressure change of a liquid enclosed in a constant volume space. The change of the pressure is proportional to the change of the temperature. A possible realization of this device can be seen of *Figure 4.1*. The chamber containing the liquid is denoted by 1. The capillary tube (2) is also filled with the liquid, e.g. mercury. Due to the temperature change the expanding fluid in the tube (2) displaces the spiral spring (3), and this displacement is transferred with a lever and a rack-segment to the pointer.
- c) **Bimetallic temperature gauge:** a bimetallic strip can be naturally used to measure temperature, and it can act both as a sensor and a movable part in the instrument.

Two possible realizations of this instrument are depicted on *Figure 4.2*. The bimetal strip consists of two different metals, and one of them has a significantly smaller linear thermal expansion coefficient than the other one. The two metal pieces are fixed to each other, and a change in the temperature results in the bending of the bimetal strip. This deformation can be converted to a pointer.

- d) **Thermocouple:** this device is based on the phenomenon that, when two materials with different conduction properties are joined together firmly at one end, at their other end a nonzero voltage can be measured. This voltage depends on the materials, and also on the temperature. *Figure 4.3* shows two different variations of this circuit. Thermocouples can be used in the temperature range 300-1600 °C. An advantage of this type of instrument is that the sensor is very small, therefore the measurement can be carried out in a small volume.

Thermocouples are operated in the following way: the reference point is kept at a constant temperature. In practice, this can be achieved by using melting ice (for this reason, this point can be called a cold point). The point at which the two metals are joined is the part with which the temperature is measured. If the temperature of the reference point is kept constant, then the voltage is the function of the measurement point temperature.

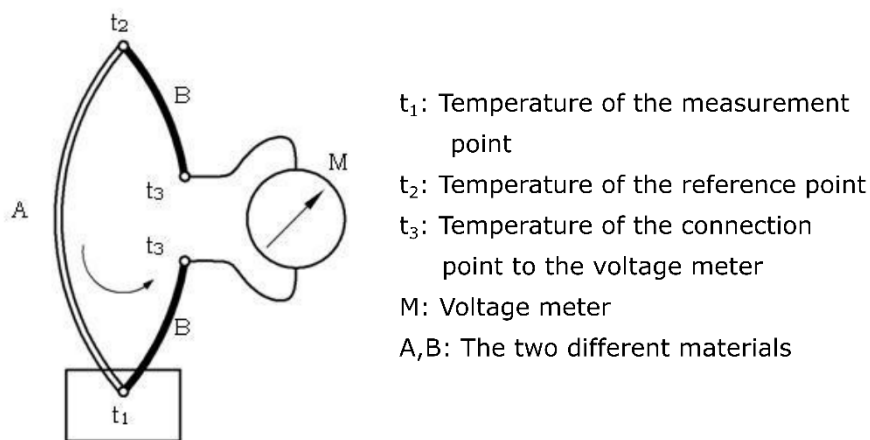

Figure 4.3. Schematics of thermocouples

### 3. The measurement

In this section, the measurement equipment, its key parameters and different operational states are covered. This is followed by a brief description of the measurement, and the minimum requirements for participation in the laboratory measurements. Acquiring the knowledge described in this section is crucial in order to perform the measurement successfully.

#### 3.1 The measuring equipment

The measuring equipment is a flow-through type water heater. The schematics of the device are shown on *Figure 4.4*, and a picture of the actual equipment can be seen in *Figure 4.5*.

The mass flow rate  $\dot{m}$  can be adjusted with the valve SZ, and can be calculated from the volumetric flow rate. The volumetric flow rate is obtained by measuring the time ( $t_k$ ) with a stopwatch under which a volume meter tank with volume  $V$  is filled. The electrical heater (F), consists of the power supply (TE) and switch (K). The temperature of the water entering the device is measured with the glass thermometer ( $T_1$ ), and the outflowing water temperature is measured with the glass thermometer ( $T$ ). The voltage of the heater is measured with the voltage meter (U), and the electric current flowing through it with the current meter (I). The role of the pressure gauge, which measures the pressure just before the valve, is to help us adjust the mass flow rate properly to cover the operating range of this device.

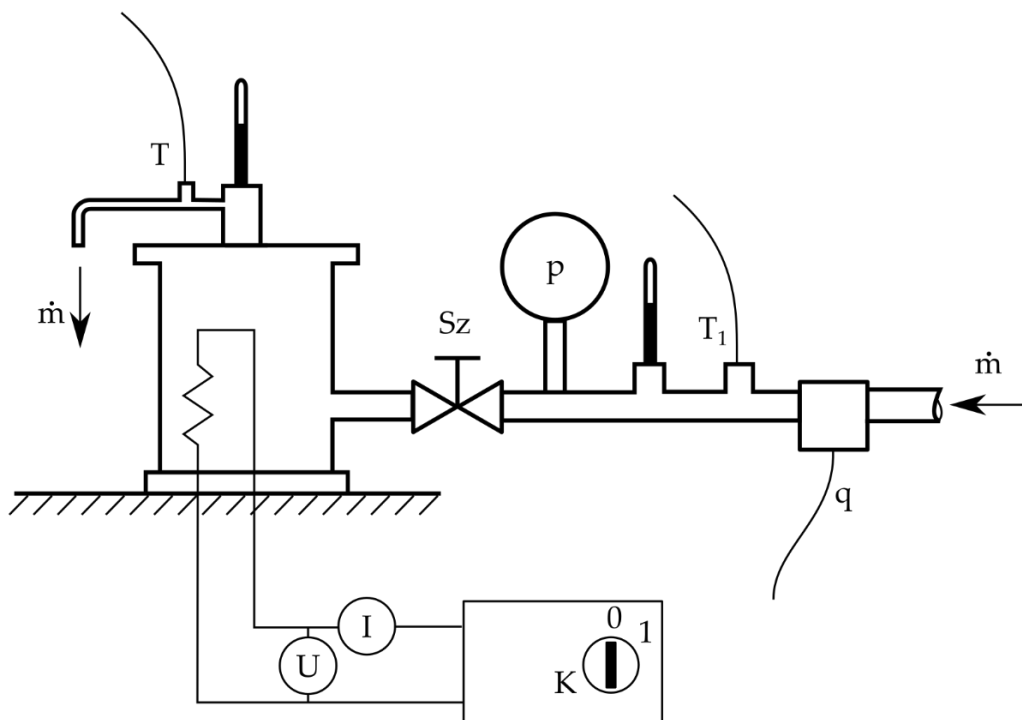

Figure 4.4. The measuring equipment.

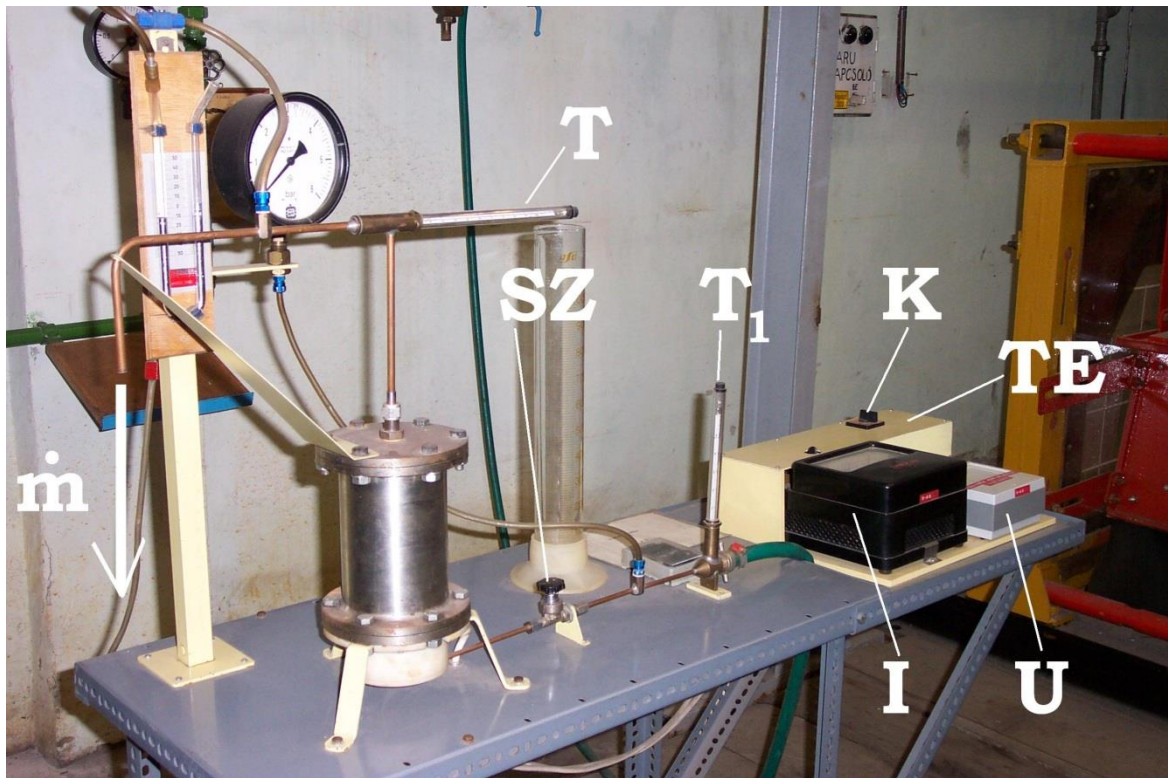

Figure 4.5. Photograph of the measuring equipment

### 3.2 The equations of the water heater

The equation of the power transport of the flow-through water heater with the notations of Figure 4.6 is

$$\dot{m} \cdot i_{t1} + P_e = \dot{m} \cdot i_{t2} + P_{env}. \quad (8)$$

The different quantities in the equation are the following

- $\dot{m}$  the mass flow rate of the water (kg/s),
- $i_{t1}$  the total specific enthalpy of the water entering the system (J/kg),
- $i_{t2}$  the total specific enthalpy of the water leaving the system (J/kg),
- $P_e$  the power input of the electric heater (W),
- $P_{env}$  the heat loss, which is transferred to the environment (W).

Upon reordering equation (8), we obtain

$$P_e = \dot{m}(i_{t2} - i_{t1}) + P_{env} = P_1 + P_{env}, \quad (9)$$

which means that the power supplied to the electric heater raises the total enthalpy of the water but some of the power (inevitably) heats the environment of the heater.

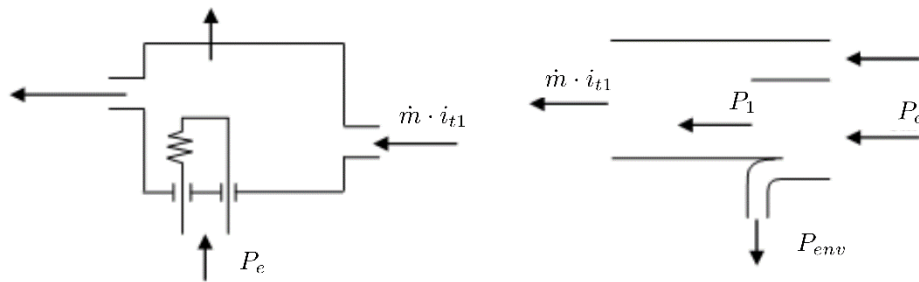

Figure 4.6. The energy transfer in the heater

After turning on the device, the temperature  $T$  of the water leaving the device with mass flow rate  $\dot{m}$  starts to increase but after some time it approaches a certain value. This so-called transient process, which is due to the heating up of the device, can be approximated very well by the following dimensionless equation (the derivation of this equation can be found on page 12):

$$T^* = 1 - e^{-t^*} \quad (10)$$

$$T^* = \frac{\Delta T}{\Delta T_{steady}} \quad \text{dimensionless temperature change} \quad (11)$$

$$\Delta T = T - T_1 \quad \text{the time-dependent temperature difference (}^\circ\text{C)} \quad (12)$$

$$\Delta T_{steady} = T_{steady} - T_1 \quad \text{the steady state temperature difference (}^\circ\text{C)} \quad (13)$$

$$T_{steady} \quad \text{steady state outflow temperature (}^\circ\text{C)}$$

$$T_1 \quad \text{temperature of the water entering the system}$$

$$c_v \quad \text{specific heat capacity of the water (J/kg/K)}$$

$$t^* = \frac{t}{\tau} \quad \text{dimensionless time (-)} \quad (14)$$

$$t \quad \text{time elapsed from the instant of turning on the machine (s)}$$

$$\tau = \frac{m_{lumped}}{\dot{m}} \quad \text{the characteristic time of the machine (s)} \quad (15)$$

$m_{lumped}$  lumped mass of the machine (for details see the inset at the end of the text)

Neglecting  $P_{env}$  and losses associated with the fluid flow, the equation of the steady state temperature rise is the following:

$$\Delta T_{steady} \approx \frac{P_e}{c_v \dot{m}} \quad (16)$$

In the case a fixed electrical power input, the function  $\Delta T_{steady}(\dot{m})$  ( $\Delta T_{steady}$  as the function of  $\dot{m}$ ) is a hyperbolic curve, which has  $P_e$  as a parameter (that is, different hyperbolae for different  $P_e$  values). This can be seen in *Figure 4.8*. With this curve, arbitrary parameter



combinations of the machine can be evaluated, e.g. given a mass flow rate  $\dot{m}$ , for different electrical power inputs the steady temperature raise  $\Delta T_{steady}$  can be easily evaluated.

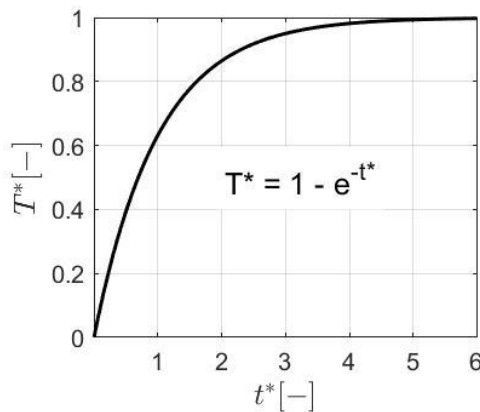

Figure 4.7. The dimensionless heat-up curve

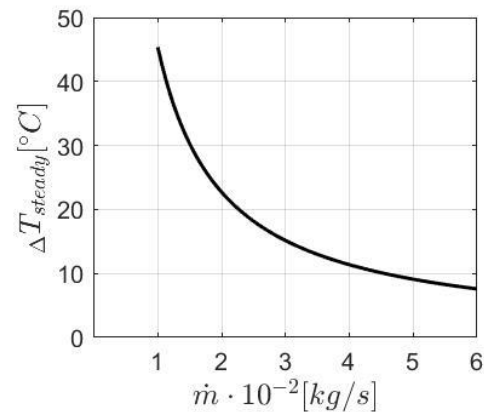

Figure 4.8. The steady state temperature as the function of the mass flow rate

### 3.3 The measurement tasks

#### Measurement of the heat-up process:

- First, a small mass flow rate should be set, and also the mass flow rate should be measured with the metering glass and the stopwatch. It is important be continuous i.e. the water should not come out in droplets. (Watch out! The outflowing water might be very hot!)
- After this, the characteristic time of the device should be calculated. The value of  $m_{lumped}$  is already known, and will be given at the start of the measurement.
- After turning on the electrical heating, the temperature  $T$  and the time  $t$  should be written down until the steady state temperature is reached. This can be expected approximately after  $t > 3\tau$  time. It is sufficient to record the temperature  $T$  at the ends of  $0.5\tau$  long intervals, and these time instants can and should be rounded to the nearest integer value (clearly, you do not want to read the values at every 4.86 seconds, but rather at every 5 seconds). 6 or 7  $t$ - $T$  pairs should be enough. The approximately constant quantities ( $U$  voltage,  $I$  current) should be recorded only once.
- The data points should be plotted on the previously prepared heat-up chart, which can be seen on *Figure 4.7*.

The first row of the table for the measurement data and the calculations should be the following:

No.	$t$	$T$	$\Delta T$	$t^*$	$T^*$
	(s)	(°C)	(°C)	(-)	(-)

The quantities that should be measured only once and the physical constants are the following:

$U$	=	(-)	voltage as read from the instrument
$I$	=	(-)	current as read from the instrument
$P_e = c_p UI$	=	(W)	electric power
$V$	=	(m <sup>3</sup> )	volume of the metering glass
$t_k$	=	(s)	time of the mass flow measurement
$T_1$	=	(°C)	temperature of the water flowing in
$\dot{m} = \frac{V}{t_k} \rho_v$	=	(kg/s)	mass flow rate
$m_{lumped}$	=	(kg)	lumped mass of the device
$\tau = \frac{m_{lumped}}{\dot{m}}$	=	(s)	characteristic time
$\rho_v$	=	1000 (kg/m <sup>3</sup> )	density of water
$c_p = CU \cdot CI$	=	1[V] · 0.25 [A]	coefficient of the instruments
$c_v$	=	4187 [J/(kg°C)]	specific heat capacity of water

**Measurement of the steady state (characteristic curve measurement):**

- The power input should be set to  $P_{env} = 1.9 \text{ kW}$  (the precise value should be recorded only once as a constant). After this, 5-6 different  $\dot{m}$  values should be adjusted and measured. In the steady state operational stage (after  $t > 3\tau$ ), the temperature of the outflowing water no longer increases, and the steady state parameters of the device should be recorded.
- Plotting the curves to the previously prepared steady state chart, which can be seen on *Figure 4.8*. The difference from the theoretical hyperbolic curve is proportional to the power transferred to the environment,  $P_{env}$ .

The first row of the table for the measurement data should be the following:

No.	$V$	$t_k$	$T_{steady}$	$\dot{m}$	$T_1$	$\Delta T_{steady}$
	(l)	(s)	(°C)	(kg/s)	(°C)	(°C)

### 3.4 Preparation for the measurement

- The students should bring one A4 size paper, plotting paper, pencil, ruler and a calculator.
- On the standing paper, on the upper half the heat-up chart, and on the bottom half the steady-state temperature chart should be prepared prior to the measurement exercise (Figures 4.7 and 4.8). **This is a prerequisite in order to participate in the measurement.** Since the Figures 4.7-4.8 are only illustrations to demonstrate the behaviour of the theoretical curves given by equations (10) and (16), **the curves should be drawn using equations (10) and (16) with the evaluation of the functions in at least 15 distinct points.** For the steady state chart, the value  $P_e = 1.9$  [kW] should be used. The recommended ranges from the axes of the charts are the following:  $t^* \in [0,5]$ ;  $T^* \in [0, 1]$ ;  $\dot{m} \in [0, 0.06][\frac{kg}{s}]$ ;  $\Delta T_{steady} \in [0, 70][°C]$ . In the evaluation of the measurement, equations (11) and (13) should be used.
- At the start of the measurement session, it will be checked whether or not the students are prepared to participate in the measurement. **This will be carried out by a test, which covers the equations used during the measurement exercise.** The test consists of theoretical questions and short calculation exercises. Most of these questions can be found on the website of the Department of Hydrodynamic Systems.
- The first 4 sections of the template of the measurement report should be filled before the measurement (sections 5-9 will be filled during the measurement).

Questions or remarks regarding the measurement description document or the measurement should be sent to the e-mail address [aszabo@hds.bme.hu](mailto:aszabo@hds.bme.hu).



Here we present a possible derivation of the theoretical heat-up curve in concordance with the theoretical lectures. The notations used here coincide with those of *Figures 4.4* and *4.6*, furthermore  $m_0$  denotes the total mass of the heater (both the body and the base), and  $c_f$  denotes its specific heat capacity.

We aim at deriving the temperature-time function of the heat-up process. The heat transport to the environment is neglected. Moreover, we assume that the temperature of the water heater and the outflowing water are the same.

During a  $\Delta t$  time interval  $P_e \Delta t$  heat is supplied to the system, from which  $m_0 c_f \Delta T$  thermal energy heats up the heater, and the water absorbs  $\Delta t \dot{m} c_v (T - T_1)$ . From this information, the equation of energy transfer in the device is the following:

$$P_e \Delta t = m_0 c_f \Delta T + \dot{m} c_v \Delta t (T - T_1). \quad (17)$$

Let us define the so-called lumped mass of the system:

$$m_{lumped} c_v = m_0 c_f. \quad (18)$$

Substituting this to equation (17), we get

$$1 = \frac{m_{lumped} c_v}{P_e} \frac{\Delta T}{\Delta t} + \frac{\dot{m} c_v}{P_e} (T - T_1). \quad (19)$$

Equation (19) could be used to calculate the heat-up curve, however, it contains a few different parameters ( $m_{lumped}$ ,  $c_v$ ,  $P_e$ ) characterizing the device. We want to simplify this by deriving a general function which describes all water heaters which are similar to ours. To achieve this, further simplifications are needed. Let us introduce the following dimensionless variables:

$$T^* = \frac{\dot{m} c_v}{P_e} (T - T_1), \quad (20)$$

$$\Delta T^* = \frac{\dot{m} c_v}{P_e} \Delta T, \quad (21)$$

$$\Delta t^* = \Delta t \frac{\dot{m}}{m_{lumped}}. \quad (22)$$

Substituting these formulae to equation (19), we get

$$1 = \frac{\Delta T^*}{\Delta t^*} + T^* = \frac{dT^*}{dt^*} + T^*. \quad (23)$$

If  $\Delta t^*$  and  $\Delta T^*$  both approach zero, then the division of the differences is the derivative.

This equation is a so-called **differential equation**, which contains not only the unknown function  $T^*(t^*)$ , but also its derivative. The solution of this differential equation is the function  $T^*(t^*)$ . The methods for these types of equations will be covered in the higher semesters, however, checking the validity of the solution requires only differentiation and is pretty straightforward. The solution of equation (23) is

$$T^* = 1 - e^{-t^*} \quad (24)$$

which also appears on *Figure 4.7*. Differentiation this with respect to  $t^*$  yields

$$\frac{dT^*}{dt^*} = e^{-t^*}. \quad (25)$$

With this, checking the validity of the solution is pretty easy:

$$1 = e^{-t^*} + 1 - e^{-t^*} = 1. \quad (26)$$