

Volumetric Pumps and Compressors

lecture notes

Csaba Hős

Csaba Bazsó

Péter Haraszti

October 10, 2017

Contents

1	Introduction	4
1.1	Pumps - general introduction	4
1.1.1	Turbopumps	5
1.1.2	Positive displacement pumps	7
1.2	Basic characteristics of positive displacement machines	9
2	Reciprocating Pumps	11
2.1	Single-acting piston pumps	11
2.2	Multiple piston pumps	13
2.3	Axial piston pumps	13
2.4	Radial piston pumps	15
2.5	Diaphragm pumps	16
2.6	Cavitation	16
3	Rotary pumps	18
3.1	Gear pumps	18
3.1.1	External gear pumps	18
3.1.2	Internal gear pumps	18
3.2	Screw pump	19
3.3	Vane pump	20
3.4	Progressing cavity pump (eccentric screw pump)	21
3.5	Peristaltic pump	21
4	Hydraulic cylinders	23
5	Pulsation dampener	24
6	Pressure relief valves (PRV)	28
6.1	Direct spring loaded hydraulic PRV	28
6.2	Pilot operated pressure relief valve	30
6.3	Sizing of a pressure relief valves, hydraulic aggregate	30
7	Sizing of simple hydraulic systems	32
7.1	Aggregate with hydraulic motor	32
7.2	System with cylinder	32
7.2.1	Example for a system with cylinder	33
7.3	Control techniques	34
7.3.1	Throttle valve in parallel connection	34
7.3.2	Throttle valve in series connection	36

8 Compressors	38
9 TODO	39

1 Introduction

1.1 Pumps - general introduction

A pump is a machine that moves fluids (mostly liquids) by mechanical action. Pumps can be classified into three major groups according to the method they use to move the fluid:

Centrifugal pumps are used to transport fluids by the conversion of rotational kinetic energy to the hydrodynamic energy of the fluid flow. The rotational energy typically comes from an engine or electric motor. The fluid enters the pump impeller along or near to the rotating axis and is accelerated by the impeller. Common uses include water, sewage, petroleum and petrochemical pumping.

Positive displacement pumps have an expanding cavity on the suction side and a decreasing cavity on the discharge side. Liquid flows into the pumps as the cavity on the suction side expands and the liquid flows out of the discharge as the cavity collapses. The volume is constant given each cycle of operation.

Miscellaneous pumps are the rest of the pumps, such as Eductor-jet pump, airlift pump, etc.

Pumps operate by some mechanism (typically reciprocating or rotary), and consume energy to perform mechanical work by moving the fluid. Pumps operate via many energy sources, including manual operation, electricity, engines, or wind power, come in many sizes, from microscopic for use in medical applications to large industrial pumps.

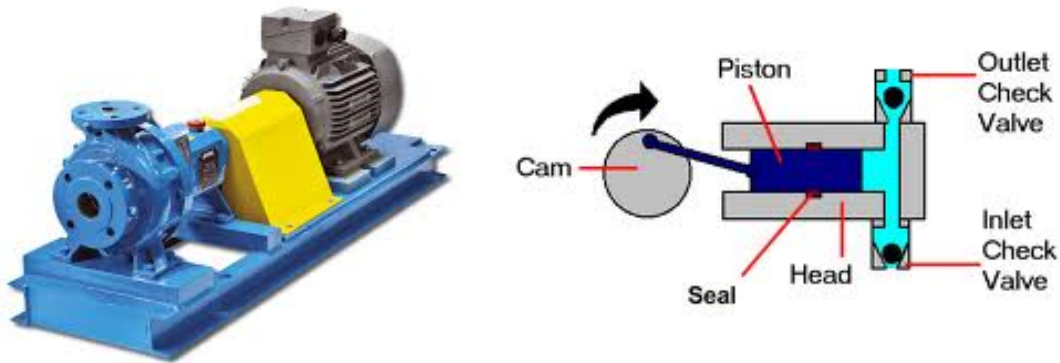

Figure 1: Two examples of pumps: (left) centrifugal pump (right) positive displacement pump (piston pump)

Mechanical pumps serve in a wide range of applications such as pumping water from wells, aquarium filtering, pond filtering and aeration, in the car industry for water-cooling and fuel injection, in the energy industry for pumping oil and natural gas or for operating cooling towers. In the medical industry, pumps are used for biochemical processes in developing and manufacturing medicine, and as artificial replacements for body parts, e.g. the artificial heart.

The two most important quantities characterizing a pump are the pressure difference between the suction and pressure side of the pump Δp and the flow rate delivered by the pump Q . For practical reasons, in the case of water technology, the *pressure head* is usually used, which is pressure given in meters of fluid column: $H = \frac{\Delta p}{\rho g}$. Simple calculations reveals that for water 1 bar (10^5 Pa) pressure is equivalent of 10 mwc (meters of water column).

1.1.1 Turbopumps

In the case of a turbopump, a rotating impeller adds energy to the fluid. The head is computed with the help of Euler's turbine equation

$$H = \frac{c_{2u}u_2 - c_{1u}u_1}{g} \Big|_{c_{1u}=0} = \frac{c_{2u}u_2}{g} \quad (1)$$

while the flow rate is

$$Q = D_2 \pi b_2 c_{2m}, \quad (2)$$

with c_{2u} and c_{1u} being the circumferential component of the absolute velocity at the outlet and inlet, respectively, $u_1 = D_1 \pi n$ and $u_2 = D_2 \pi n$ the circumferential velocities. c_{2m} stands for the radial (meridian) component of the absolute velocity at the outlet, D is diameter and b stand for the width of the impeller. (See Figure 2 and *Fluid Machinery* lecture notes for further details.)

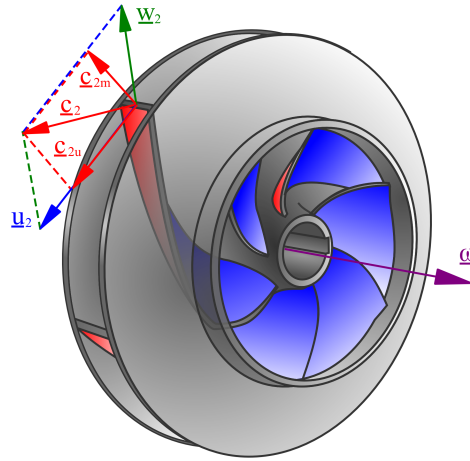

Figure 2: Velocity triangles on a centrifugal impeller.

Notice that the head (H) and flow rate (Q) are provided by the two component of the same velocity vector c_2 . Thus, if H increases, Q decreases and vice versa. Thus *in the case of turbomachines the pressure difference and the flow rate are directly connected and not independent*. This dependency is described by the pump's performance curve, see Figure 3.

An important quantity describing the shape of the impeller of a turbopump is the specific speed n_q , defined as

$$n_q = n \frac{Q_{\text{opt.}}^{1/2}}{H_{\text{opt.}}^{3/4}} \quad [\text{rpm}] \frac{[\text{m}^3/\text{s}]^{1/2}}{[\text{m}]^{3/4}}. \quad (3)$$

The dimension (unit) of n_q is not emphasised and mostly omitted. The concept of specific speed can be used to determine the pump type (i.e. radial/mixed/axial) which is capable of performing a pumping problem efficiently.

Example 1. We have to pump clean water to an upper reservoir at 60 m height. The nominal power of the driving electric motor is 5 kW, its revolution number is 3000 rpm. The flow rate is (assuming 100% efficiency)

$$P_{\text{motor}} = \Delta p \cdot Q \rightarrow Q = \frac{P_{\text{motor}}}{\Delta p} = \frac{P_{\text{motor}}}{\rho g H} = 8.49 \times 10^{-3} \text{ m}^3/\text{s} = 509 \text{ l}/\text{min} \quad (4)$$

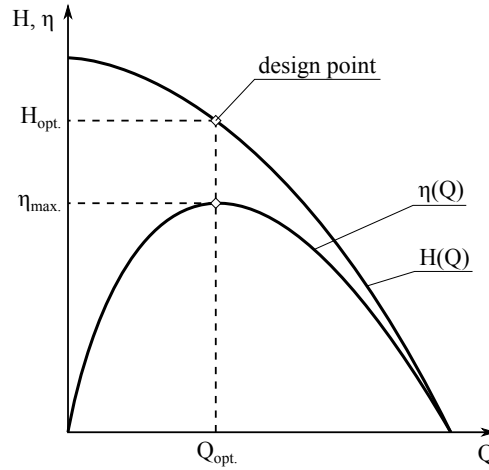

Figure 3: Turbopump performance curves

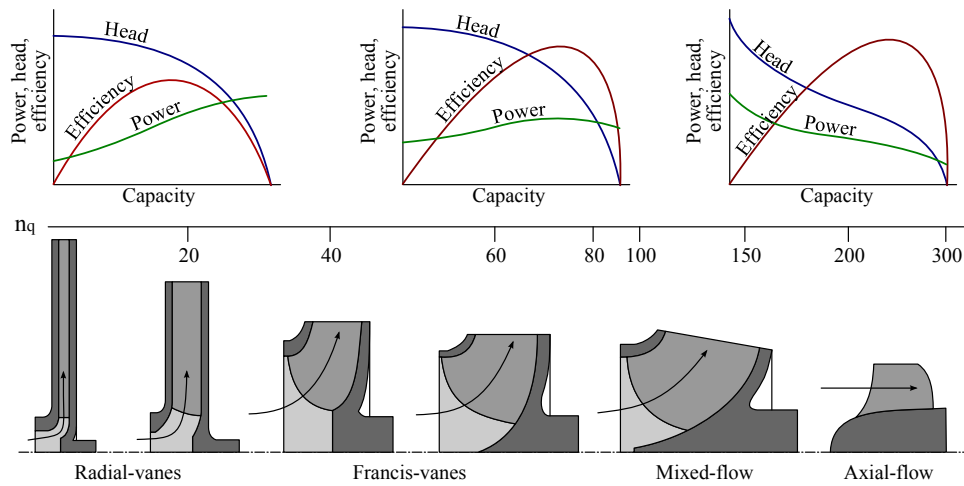

Figure 4: Turbopump performance curves

Hence the specific speed is

$$n_q = n \frac{Q_{\text{opt.}}^{1/2}}{H_{\text{opt.}}^{3/4}} = 3000 \frac{(8.49 \times 10^{-3})^{1/2}}{(60)^{3/4}} \cong 12.8, \quad (5)$$

which means that a centrifugal turbopump is suitable for this problem.

Example 2. Now consider the hydraulic cylinder depicted in Figure 5. The required pressure difference is now $\Delta p = 200\text{bar} = 2 \times 10^7\text{Pa}$, the power and the revolution number of the driving motor is the same as before (5kW, 3000rpm).

First, find the flow rate of the pump (again, assume 100% efficiency):

$$Q = \frac{P_{\text{motor}}}{\rho g H} = \frac{5000}{9810 \cdot 2000} = 2.55 \times 10^{-4} \text{ m}^3/\text{s} = 15.3 \text{ liter}/\text{min}, \quad (6)$$

which gives

$$n_q = n \frac{Q_{\text{opt.}}^{1/2}}{H_{\text{opt.}}^{3/4}} = 3000 \frac{(2.55 \times 10^{-4})^{1/2}}{(2000)^{3/4}} = 0.16. \quad (7)$$

Comparing this value with Figure 4 we see that this value is 'off' the chart. Such a small n_q value would require an extremely large-diameter impeller, which is very thin. Besides the problems with the high centrifugal stresses,

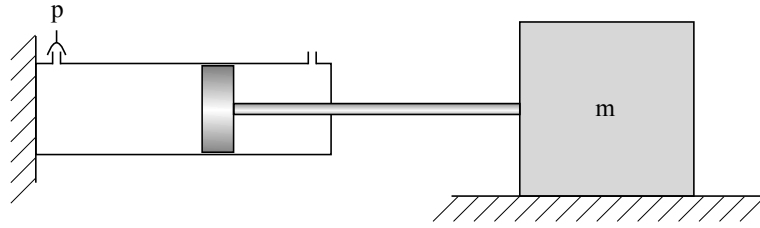

Figure 5: Simple sketch of a hydraulic cylinder

from the fluid mechanical point of view, such a thin impeller introduces extremely large fluid friction resulting in poor efficiency. Thus we conclude that **pumping problems resulting in high pressure difference and low flow rates (i.e. $n_q < \text{say}, 10$) cannot be efficiently solved by centrifugal pumps.**

1.1.2 Positive displacement pumps

Positive displacement pumps (PDPs) are typically used in high-pressure (above $\Delta p > 10\text{bar}$, up to 1000-2000 bars) technology, with relatively low flow rate. These machines have an expanding cavity on the suction side and a decreasing cavity on the discharge side. Liquid flows into the pumps as the cavity on the suction side expands and the liquid flows out of the discharge as the cavity collapses. The volume is constant given each cycle of operation.

The positive displacement pumps can be divided in two main classes (see Figures XXX)

- reciprocating
 - piston pumps
 - plunger pumps
 - diaphragm pumps
 - axial/radial piston pumps
- rotary
 - gear pumps
 - lobe pumps
 - vane pumps
 - progressive cavity pumps
 - peripheral pumps
 - screw pumps

PDPs, unlike a centrifugal pumps, will produce the same flow at a given motor speed (rpm) no matter the discharge pressure, hence PDPs are *constant flow machines*. A PDP must not be operated against a closed valve on the discharge (pressure) side of the pump because it has no shut-off head like centrifugal pumps: a PDP operating against a closed discharge valve will continue to produce flow until the pressure in the discharge line are increased until the line bursts or the pump is severely damaged - or both.

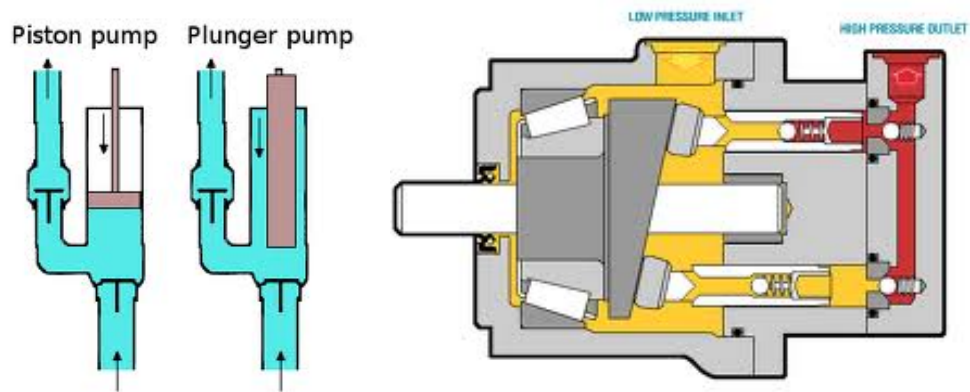

Figure 6: Some reciprocating pumps

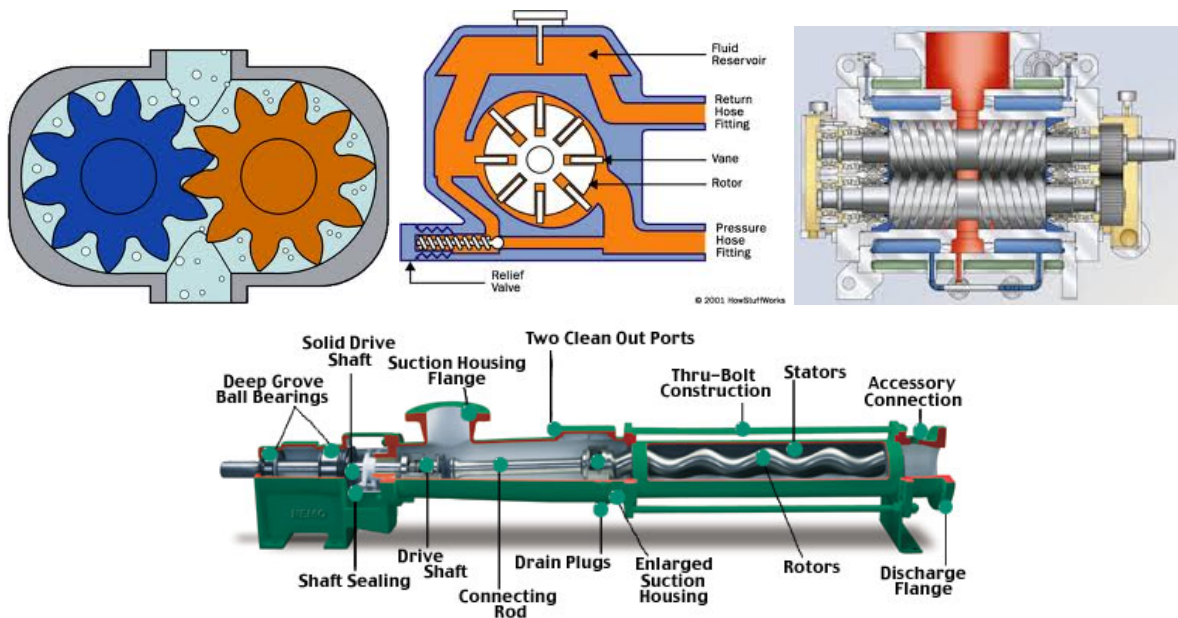

Figure 7: Some rotary pumps

A relief or safety valve on the discharge side of the PDP is therefore absolute necessary. The relief valve can be internal or external. The pump manufacturer has normally the option to supply internal relief or safety valves. The internal valve should in general only be used as a safety precaution, an external relief valve installed in the discharge line with a return line back to the suction line or supply tank is recommended.

Several types of PDPs can be used as motors: if fluid is driven through them (e.g. gear pump), the shaft rotates and the same machine can be used as a motor.

1.2 Basic characteristics of positive displacement machines

The pump *displacement* V_g is the volume of the liquid delivered by the pump per one revolution, assuming no leakage (zero pressure difference between the suction and pressure side) and neglecting the fluid compressibility. The *ideal – theoretical – flow rate* is

$$Q_{th} = nV_g \quad (8)$$

where Q_{th} is theoretical flow rate (liter/min), n is the revolution number of the pump shaft (rpm) and V_g stands for the pump displacement, (cm^3).

In the case of **pumps**, the actual outflow is less than the theoretical flow rate, due to the leakages inside the pump. These losses are taken into by the *volumetric efficiency* η_{vol} : $Q = \eta_{vol}Q_{th} = \eta_{vol} n V_g$. Other types of losses (sealing, bearing, fluid internal and wall friction) are all concentrated into the so-called *hydromechanical efficiency* η_{hm} , which connects the input and output power: $P_{in}\eta_{hm} = P_{out}$. For pumps, $P_{in} = M\omega$ and $P_{out} = Q\Delta p$. We have:

$$\underbrace{\eta_{hm} M 2\pi n}_{P_{in}} = \underbrace{nV_g \eta_{vol} \Delta p}_{P_{out}} \rightarrow \Delta p_{pump} = \frac{2\pi M}{V_g} \frac{\eta_{hm}}{\eta_{vol}} \quad (9)$$

In the case of **motors**, the input power is hydraulic power ($P_{in} = Q\Delta p$) and the output is rotating mechanical power $P_{out} = M\omega$. Due to the internal leakage, one has to 'push' more fluid into the pump to experience the same revolution number, hence $Q = Q_{th}/\eta_{vol} > Q_{th}$. We have:

$$\underbrace{\eta_{hm} \frac{nV_g}{\eta_{vol}} \Delta p}_{P_{in}} = \underbrace{M 2\pi n}_{P_{out}} \rightarrow \Delta p_{motor} = \frac{2\pi M}{V_g} \frac{\eta_{vol}}{\eta_{hm}} \quad (10)$$

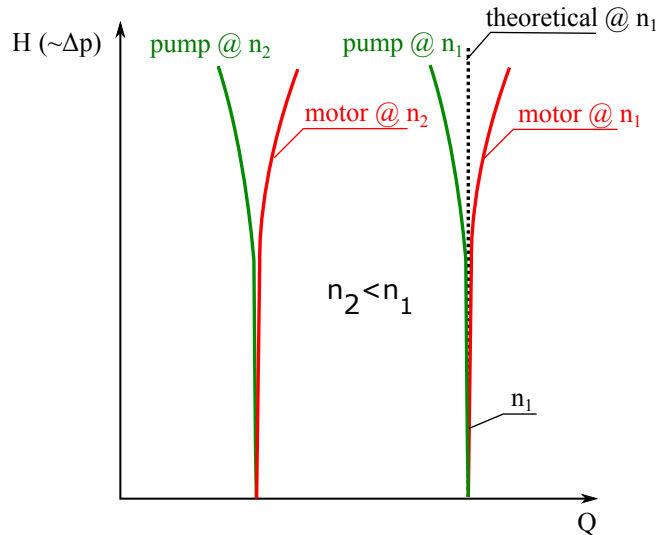

Figure 8: Pump and motor performance curves for two different revolution numbers.

We conclude that for both pumps and motors,

$$Q \propto n, V_g \quad \text{and} \quad \Delta p \propto M, \frac{1}{V_g}.$$

(11)

Which means that the pressure and the flow rate are independent for a given machine. The same behaviour can be observed on the performances curve of these machines, see Figure 8. The theoretical performance lines are vertical for a given revolution speed, meaning that the theoretical flow rate does not change when varying the pressure.

However, the leakage flow rate through the small internal gaps of the pumps (motors) slightly change this theoretical behaviour. In the case of pumps, a portion of the flow rate flows back from the pressure side to the suction side through these gaps, hence reducing the outflow of the pump. The higher the pressure difference is, the higher the leakage flow rate is, hence the pump performance curves tend to ‘bend to the left’ from the vertical, theoretical line. In the case of motors, where the fluid drives the shaft, we need larger flow rates to reach the desired revolution number, hence the real curves ‘bend to the right’.

2 Reciprocating Pumps

Piston/plunger pumps comprise of a cylinder with a reciprocating piston/plunger in it. In the head of the cylinder the suction and discharge valves are mounted. In the suction stroke the plunger retracts and the suction valves opens causing suction of fluid into the cylinder. In the forward stroke the plunger push the liquid out the discharge valve.

With only one cylinder the fluid flow varies between maximum flow when the plunger moves through the middle positions, and zero flow when the plunger is in the end positions. A lot of energy is wasted when the fluid is accelerated in the piping system. Vibration and "water hammers" may be a serious problem. In general the problems are compensated by using two or more cylinders not working in phase with each other.

Several cylinders can be mounted to the same shaft: pumps with 1 cylinder are called *simplex* pumps, *duplex* pumps have two cylinders (with π phase shift) while *triplex* pumps have three pumps with $2\pi/3 = 120$ degrees phase shift. Pumps with even more pistons (5,7,9) are also common. Pumps with both sides of the piston acting (being in contact with the liquid) are called *double-acting* pumps.

2.1 Single-acting piston pumps

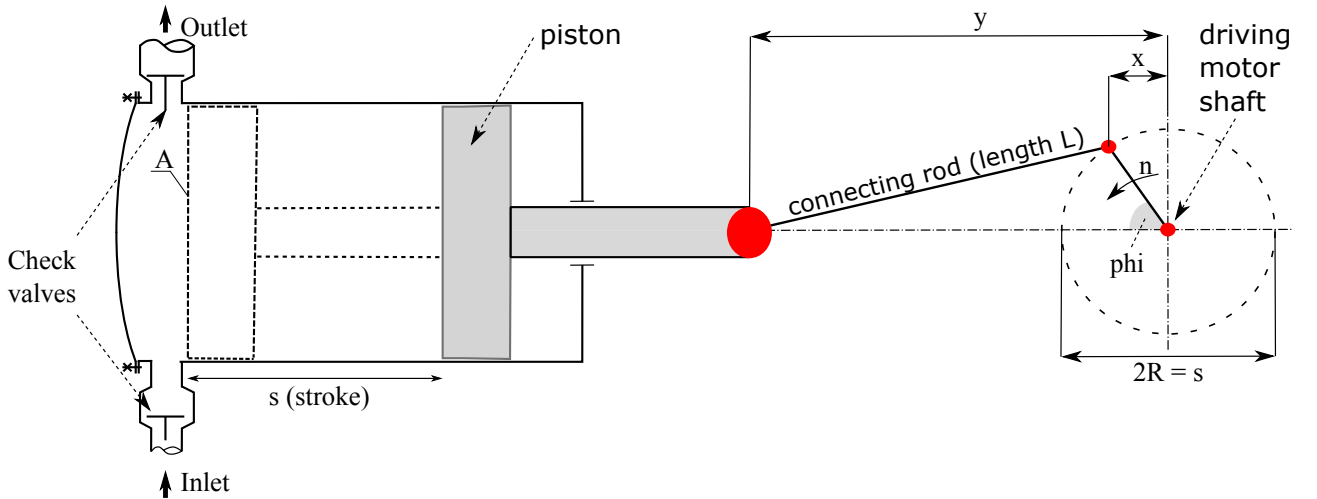

Figure 9: Single-acting piston pump

Consider the piston pump depicted in Figure 9. First, let us find the $x(t)$ displacement of the piston as a function of time. By virtue of the cosine law, we have

$$L^2 = R^2 + y(t)^2 - 2Ry(t) \cos \varphi \quad \rightarrow \quad y(t) = R \cos \varphi \pm \sqrt{L^2 + R^2 (\cos^2 \varphi - 1)} \quad (12)$$

with $\varphi = \omega t$. Notice that if $\varphi = 0$, we must have $y(0) = R + L$, hence we need the 'plus' case in the above equation. The piston displacement is

$$x(t) = y(\pi/2) - y(t) = -R \cos \varphi + L \left(\sqrt{1 - \lambda^2} - \sqrt{1 - \lambda^2 \sin^2 \varphi} \right), \quad (13)$$

with $\lambda = R/L$. Now consider the second term, especially the one multiplying L . If λ is 'small enough', this term is approximately zero (e.g. if $\lambda = R/L = 0.2$, its maximum value is $\sqrt{1 - 0.2^2} - 1 = -0.0202$)¹ Hence if $\lambda < 0.2$

¹If you want to use what you have learned in Calculus: expand (13) into Taylor series around $\lambda = 0$ to get $x(t) \approx -R \cos \varphi - \frac{L}{2} \lambda^2 \cos^2 \varphi + \mathcal{O}(\lambda^4)$, which means that for small λ values $x(t) \approx -R \cos \varphi$.

(which is true for most real-life configurations), the piston displacement is approximately ($\varphi = \omega t = 2\pi nt$, where n is the revolution number)

$$x(t) \approx -R \cos(\omega t), \quad v(t) \approx R\omega \sin(\omega t) \quad \text{and} \quad a(t) \approx R\omega^2 \cos(\omega t). \quad (14)$$

As flow rate is $Q = Av$ and the stroke is $s = 2R$, the *instantaneous* pressure side flow rate is (see also Figure 10)

$$Q(t) = \begin{cases} A\frac{s}{2}\omega \cos(\omega t) & \text{if } \pi < \varphi = \omega t < 2\pi \\ 0 & \text{if } 0 < \varphi = \omega t < \pi \end{cases} \quad (15)$$

The mean flow rate is computed by finding the volume of the fluid pushed to the pressure side in one period, divided by the length of the period:

$$Q_{mean} = Asn, \quad (16)$$

that is, we have $V_g = As$, see (8). The maximum flow rate is (see (15))

$$Q_{max} = A\frac{s}{2}\omega = \pi Asn = \pi Q_{mean}. \quad (17)$$

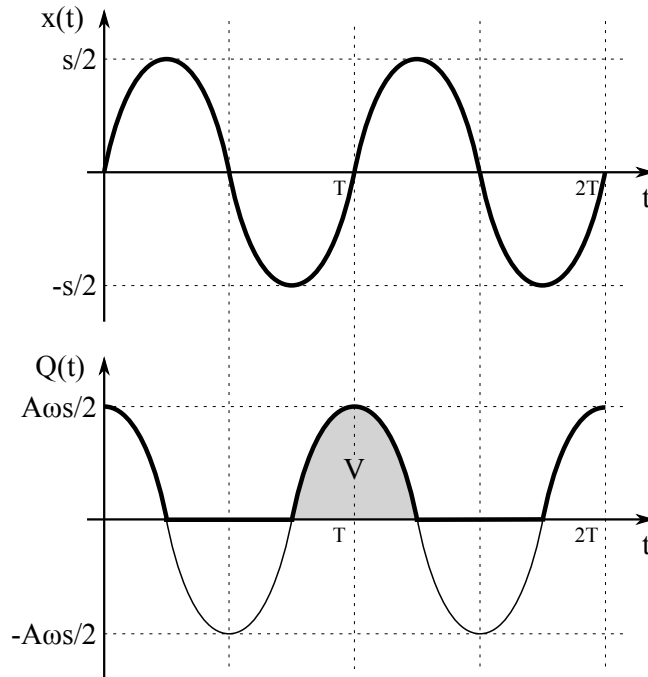

Figure 10: Piston displacement (upper panel) and flow rate (\propto velocity) curves of a single-acting piston pump.

Notice that this means that these pumps induce an extremely unsteady flow rate in the pipeline system, that varies from $Q_{min} = 0$ flow rate up to $Q_{max} = \pi Q_{mean}$ with a frequency of n (driving motor revolution number). There are two ways of reducing this pulsation: (a) by using multiple pistons or (b) adding a pulsation damper.

2.2 Multiple piston pumps

The pulsation can be reduced by adding several pistons with an evenly distributed phase shift, see e.g. Figure 11.

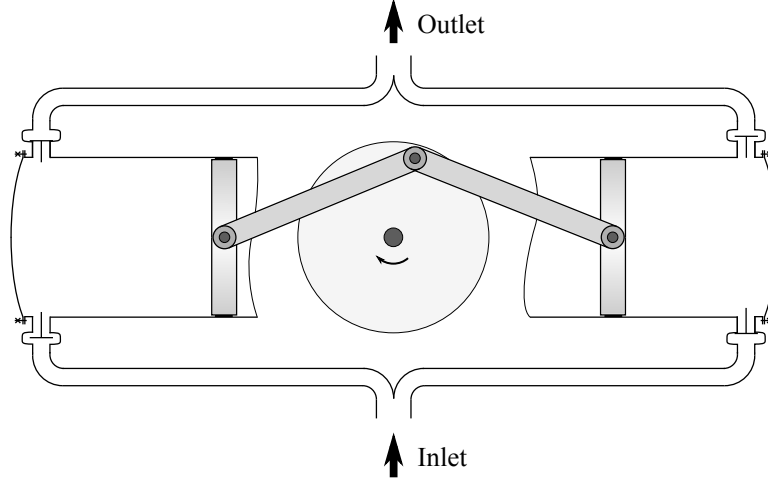

Figure 11: Double-acting piston pump

If we have three pistons (triplex), the flow rates are

$$\begin{aligned} Q_1(t) &= \max(0, Asn\pi \cos(\omega t)) \\ Q_2(t) &= \max(0, Asn\pi \cos(\omega t - \frac{2\pi}{3})) \quad \text{and} \\ Q_3(t) &= \max(0, Asn\pi \cos(\omega t - 2 \times \frac{2\pi}{3})). \end{aligned}$$

The overall flow rate is $Q(t) = Q_1(t) + Q_2(t) + Q_3(t)$. Let us define the *pulsation factor* measuring the relative flow rate change as

$$\delta = \frac{Q_{\max} - Q_{\min}}{Q_{\text{mean}}} [\%]. \quad (18)$$

For example, for a single-acting pump we have

$$\delta = \frac{Q_{\max} - Q_{\min}}{Q_{\text{mean}}} = \frac{\pi Q_{\text{mean}} - 0}{Q_{\text{mean}}} = \pi = 314\% \quad (19)$$

Similar calculation for other number of pistons gives the values in Table 1. Figure 12 depicts the flow rate for several numbers of pistons, where dashed lines are the individual flow rates while solid lines are the pump flow rate (sum of the piston flow rates) and the pulsation factor as a function of the piston number. Notice that if the number of pistons is odd (e.g. 3,5,7,9), the pulsation number is significantly lower.

Number of pistons	1	2	3	4	5	9
δ %	315	157	14	33	5	1.5

Table 1: Flow rate pulsation level as a function of the piston number.

2.3 Axial piston pumps

An axial piston pump is a positive displacement pump that has a number of pistons in a *circular array* within a cylinder block. It can be used as a stand-alone pump, a hydraulic motor or an automotive air

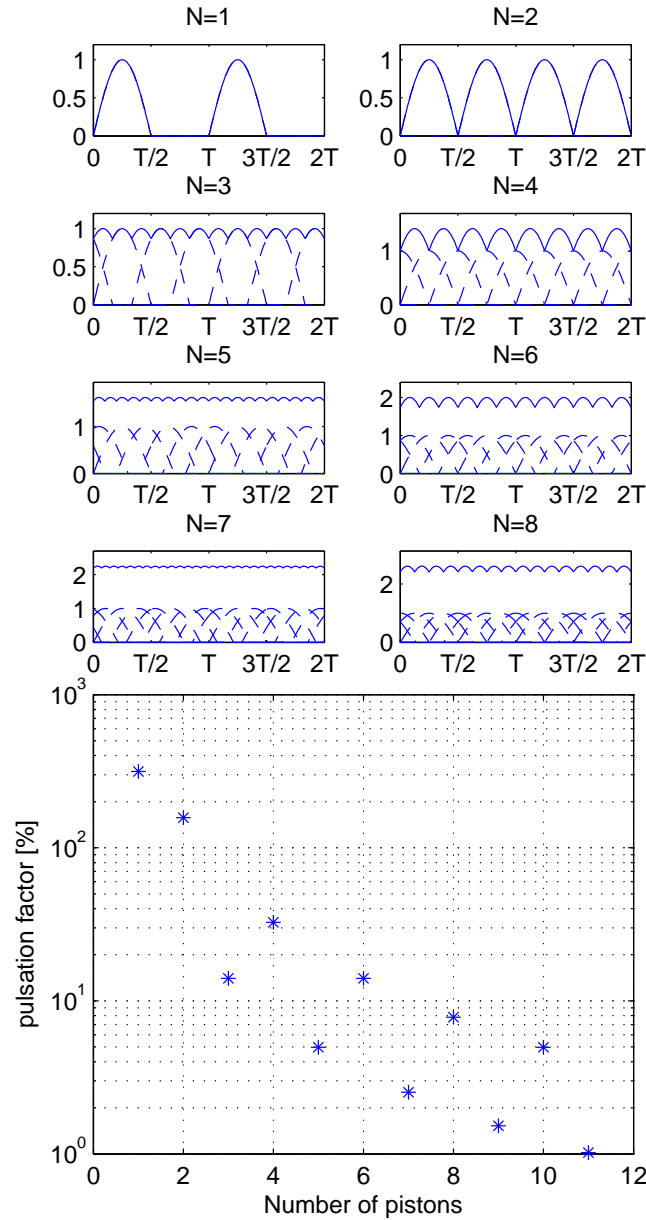

Figure 12: Pulsation factor as a function of the piston number.

conditioning compressor. Axial piston pumps are used to power the hydraulic systems of jet aircrafts, being gear-driven off of the turbine engine's main shaft. The system used on the F-14 used a 9-piston pump that produced a standard system operating pressure of 3000 psi and a maximum flow of 84 gallons per minute. Advantages:

- high efficiency
- high pressure (up to 1,000 bar)
- low flow and pressure ripple (due to the small dead volume in the workspace of the pumping piston)
- low noise level
- high reliability

Axial piston units are available in the form of pumps and motors in bent axis design or swashplate design for medium- and high-pressure ranges. They are the main components in the hydrostatic transmission.

Compact size and high power density, economy and reliability are characteristic advantages which speak for the use of hydrostatic transmissions, together with the fact that they meet the demand for high speed and high torque, as well as optimum efficiency.

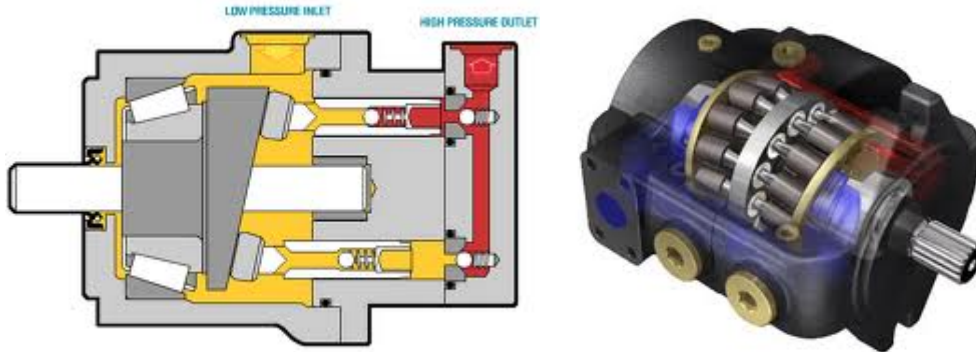

Figure 13: Axial piston pump

2.4 Radial piston pumps

In a radial piston pump the working pistons extend in a radial direction symmetrically around the drive shaft, in contrast to the axial piston pump. These kinds of piston pumps are characterized by the following advantages:

- high efficiency
- high pressure (up to 1,000 bar)
- low flow and pressure ripple (due to the small dead volume in the workspace of the pumping piston)
- low noise level
- very high load at lowest speed due to the hydrostatically balanced parts possible
- no axial internal forces at the drive shaft bearing
- high reliability

A disadvantage are the bigger radial dimensions in comparison to the axial piston pump, but it could be compensated with the shorter construction in axial direction.

Due to the hydrostatically balanced parts it is possible to use the pump with various hydraulic fluids like mineral oil, biodegradable oil, HFA (oil in water), HFC (water-glycol), HFD (synthetic ester) or cutting emulsion. That implies the following main applications for a radial piston pump: machine tools (e.g., displace of cutting emulsion, supply for hydraulic equipment like cylinders)

- high pressure units (HPU) (e.g., for overload protection of presses)
- test rigs
- automotive sector (e.g., automatic transmission, hydraulic suspension control in upper-class cars)
- plastic- and powder injection moulding
- wind energy

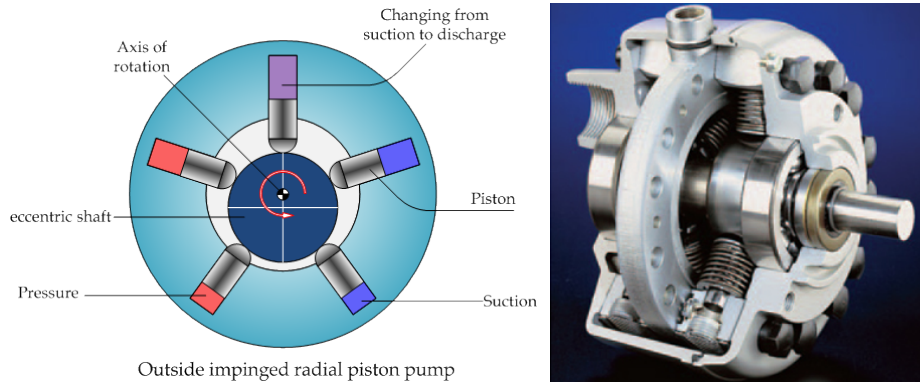

Figure 14: Radial piston pump

2.5 Diaphragm pumps

A diaphragm pump (also known as a membrane pump) is a positive displacement pump that uses a combination of the reciprocating action of a rubber, thermoplastic or teflon diaphragm and suitable valves either side of the diaphragm (check valve, butterfly valves, flap valves, or any other form of shut-off valves) to pump a fluid. The advantages of these pumps are:

- They provide *leakage-free sealing*, which can be important when pumping highly aggressive or toxic fluids.
- They have good suction lift characteristics, some are low pressure pumps with low flow rates; others are capable of higher flow rates, dependent on the effective working diameter of the diaphragm and its stroke length.
- They can handle sludges and slurries with a relatively high amount of grit and solid content.
- Suitable for discharge pressure up to 1200 bar
- They have good dry running characteristics.
- Good efficiency (can be up to 97%)
- Can handle highly viscous liquids.

However, as they are single (or sometimes double-acting) piston pumps, these pumps cause a pulsating flow that may cause water hammer, which can be minimised by using a pulsation dampener.

2.6 Cavitation

Due to the highly pulsating flow both in the suction pipeline, plus the pipe friction and geodetic height difference, the pressure at the suction manifold (where the pump is connected to the suction pipeline) might fall beneath vapour pressure, giving rise to cavitation and/or water column separation. In this section, we shall develop equations for verifying the pump (and the suction pipeline) against such malfunction.

Let us start by the Euler equation

$$\frac{\partial v_s}{\partial t} + v_s \frac{\partial v_s}{\partial s} = -\frac{1}{\rho} \frac{\partial p}{\partial s} + g - \frac{\lambda}{2D} v_s |v_s|. \quad (20)$$

Here, v_s is the velocity in the suction pipe, s is the axial coordinate along the suction-side pipeline, g is gravitational acceleration and λ is the pipe friction coefficient. Let us integrate the above equation from the suction-side tank $1=t(\text{ank})$ to the pump suction-side flange, $2=s$, that gives

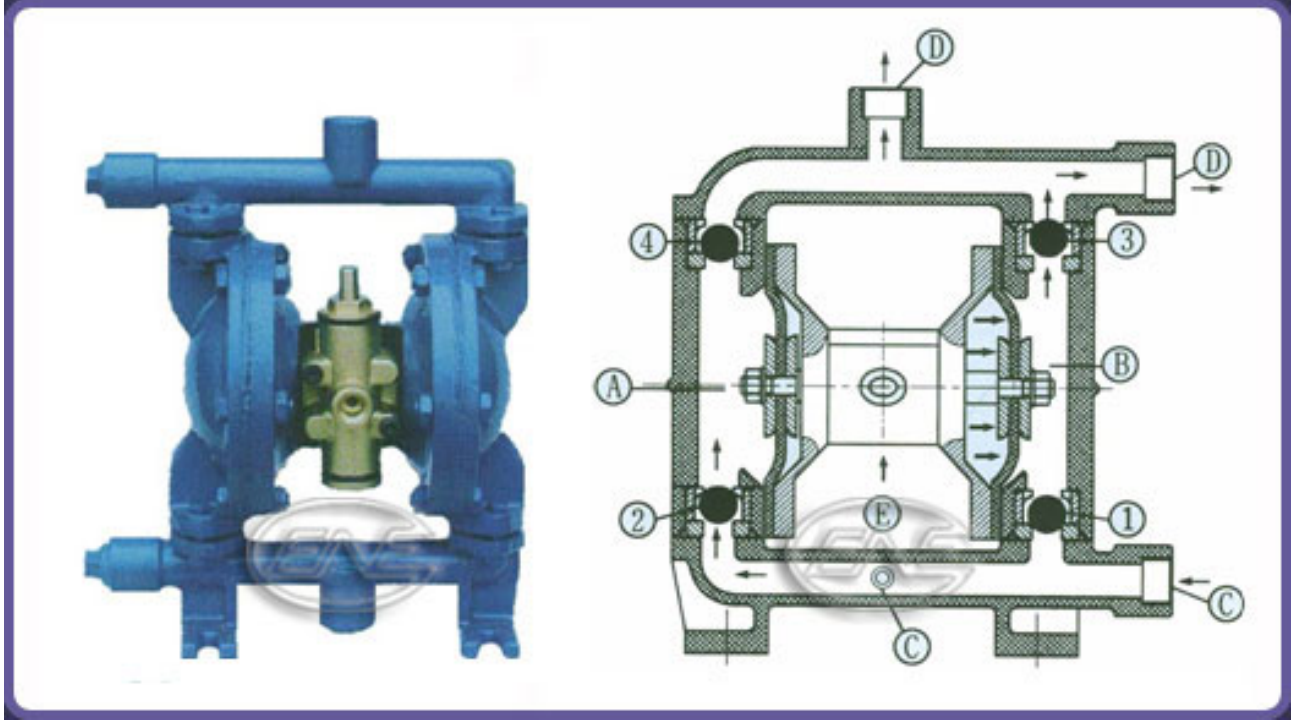

Figure 15: Diaphragm pump

$$\rho \int_1^2 \frac{\partial v_s}{\partial t} ds + \left(p_s + \frac{\rho}{2} v_s^2 + \rho g h_s \right) - \left(p_t + \frac{\rho}{2} v_t^2 + \rho g h_t \right) = \frac{\lambda L \rho}{2D} v_s |v_s|. \quad (21)$$

As the velocity in the tank is negligible ($v_t \approx 0$) and we choose the null point of the geodetic height to coincide with the tank water level ($h_t = 0$), which gives

$$p_s = p_t - \rho g h_s - \frac{\rho}{2} v_s^2 \left(1 + \lambda \frac{L}{D} \right) - \rho L \frac{dv_s}{dt}. \quad (22)$$

In order to avoid cavitation, we must have $p_s > p_{vap}$, where p_{vap} is the vapour pressure. The fluid velocity in the suction-side pipe of cross section A_s is $v_s = Q(t)/A_s$, which varies in time. Hence, we use the following conservative estimation:

$$p_{s,min} > p_t - \rho g h_s - \frac{\rho}{2} \frac{Q_{max}^2}{A_s^2} \left(1 + \lambda \frac{L}{D} \right) - \rho L \frac{\omega Q_{max}}{A_s}. \quad (23)$$

3 Rotary pumps

3.1 Gear pumps

This is the simplest of rotary positive displacement pumps consisting of two meshed gears rotating in a closely fitted casing. Fluid is pumped around the outer periphery by being trapped in the tooth spaces. It does not travel back on the meshed part, since the teeth mesh closely in the centre. It is widely used on car engine oil pumps, and also in various hydraulic power packs.

There are two main variations; external gear pumps which use two external spur gears, and internal gear pumps which use an external and an internal spur gear. Some gear pumps are designed to function as either a motor or a pump.

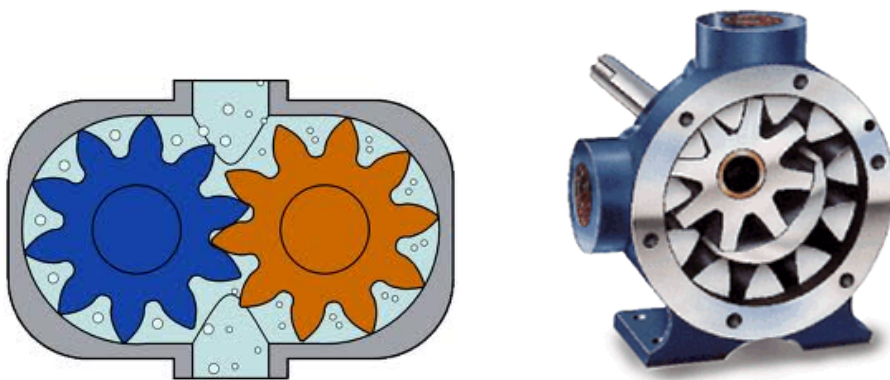

Figure 16: (left) external gear pump (right) internal gear pump

3.1.1 External gear pumps

Advantages:

- High speed
- High pressure
- Relatively quiet operation

Disadvantages:

- Four bushings in liquid area
- No solids allowed
- Fixed end clearances

Common external gear pump applications include, but are not limited to:

- Various fuel oils and lube oils
- Chemical additive and polymer metering
- Chemical mixing and blending (double pump)
- Industrial and mobile hydraulic applications (log splitters, lifts, etc.)
- Acids and caustic (stainless steel or composite construction)

3.1.2 Internal gear pumps

Advantages:

- Only two moving parts
- Only one stuffing box
- Non-pulsating discharge
- Excellent for high-viscosity liquids
- Operates well in either directions
- Low NPSH required
- Single adjustable end clearance
- Easy to maintain

Disadvantages:

- Usually requires moderate speeds
- Medium pressure limitations
- One bearing runs in the product pumped

Common internal gear pump applications include, but are not limited to:

- All varieties of fuel oil and lube oil
- Resins and polymers
- Alcohols and solvents
- Asphalt, bitumen, and tar
- Food products such as corn syrup, chocolate, and peanut butter
- Paint, inks, and pigments
- Soaps and surfactants
- Glycol

3.2 Screw pump

Screw pumps feature two or three screws with opposing thread, that is, one screw turns clockwise, and the other counterclockwise. The screws are each mounted on shafts that run parallel to each other; the shafts also have gears on them that mesh with each other in order to turn the shafts together and keep everything in place. The turning of the screws, and consequently the shafts to which they are mounted, draws the fluid through the pump. As with other forms of rotary pumps, the clearance between moving parts and the pump's casing is minimal.

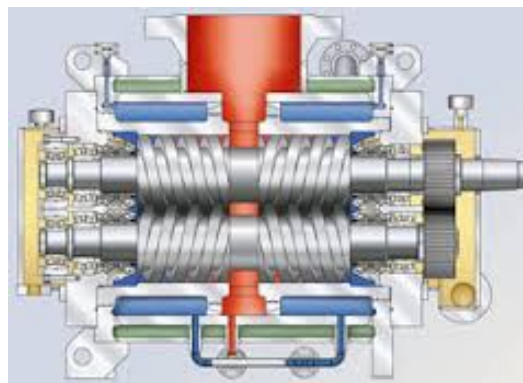
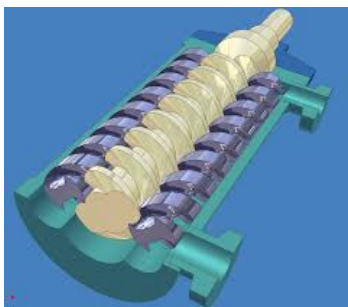

Figure 17: (left) simple screw pump (right) double-screw pump used for pumping crude oil

Advantages:

- Practically pulsation-free flow
- low fluid velocities → not sensitive for e.g. sand content

Disadvantages:

- Expensive

3.3 Vane pump

Advantages:

- Handles thin liquids at relatively higher pressures
- Sometimes preferred for solvents, LPG
- Can run dry for short periods
- Develops good vacuum

Disadvantages:

- Not suitable for high pressures
- Not suitable for high viscosity
- Not good with abrasives

Applications:

- Aerosol and Propellants
- Aviation Service - Fuel Transfer, Deicing
- Auto Industry - Fuels, Lubes, Refrigeration Coolants
- Bulk Transfer of LPG and NH₃
- LPG Cylinder Filling
- Alcohols
- Refrigeration - Freons, Ammonia

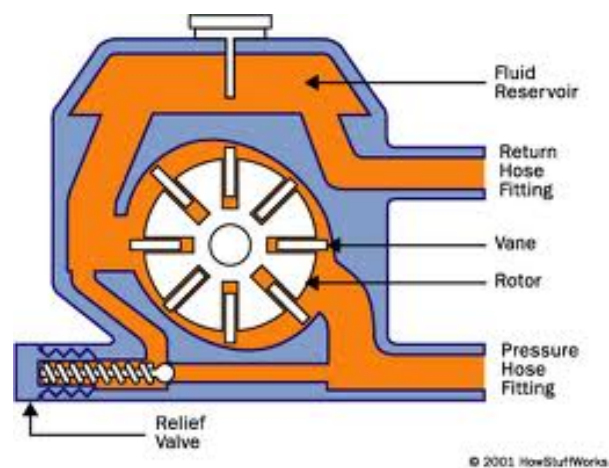

Figure 18: Vane pump

3.4 Progressing cavity pump (eccentric screw pump)

Widely used for pumping difficult materials such as sewage sludge contaminated with large particles, this pump consists of a helical shaped rotor, about ten times as long as its width. This can be visualized as a central core of diameter x , with typically a curved spiral wound around of thickness half x , although of course in reality it is made from one casting. This shaft fits inside a heavy duty rubber sleeve, of wall thickness typically x also. As the shaft rotates, fluid is gradually forced up the rubber sleeve. Such pumps can develop very high pressure at quite low volumes.

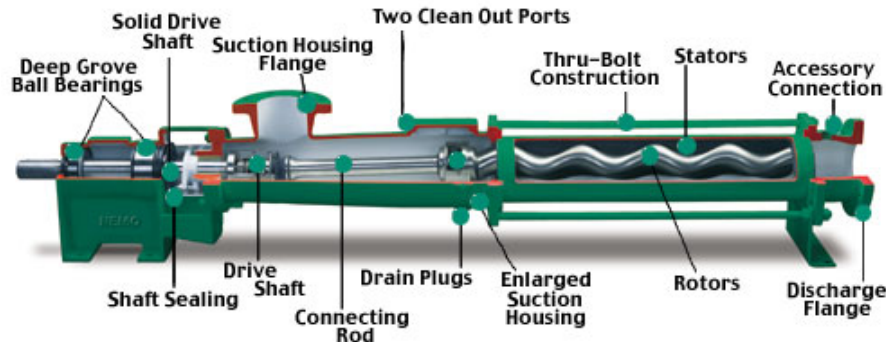

Figure 19: Progressive cavity pump.

3.5 Peristaltic pump

A peristaltic pump is a type of positive displacement pump used for pumping a variety of fluids. The fluid is contained within a flexible tube fitted inside a circular pump casing (though linear peristaltic pumps have been made). A rotor with a number of "rollers", "shoes" or "wipers" attached to the external circumference compresses the flexible tube. As the rotor turns, the part of the tube under compression closes (or "occludes") thus forcing the fluid to be pumped to move through the tube. Additionally, as the tube opens to its natural state after the passing of the cam ("restitution") fluid flow is induced to the pump. This process is called peristalsis and is used in many biological systems such as the gastrointestinal tract.

Advantages

- No contamination. Because the only part of the pump in contact with the fluid being pumped is the interior of the tube, it is easy to sterilize and clean the inside surfaces of the pump.
- Low maintenance needs. Their lack of valves, seals and glands makes them comparatively inexpensive to maintain.
- They are able to handle slurries, viscous, shear-sensitive and aggressive fluids.
- Pump design prevents backflow and syphoning without valves.[5]

Disadvantages

- The flexible tubing will tend to degrade with time and require periodic replacement.
- The flow is pulsed, particularly at low rotational speeds. Therefore, these pumps are less suitable where a smooth consistent flow is required. An alternative type of positive displacement pump should then be considered.

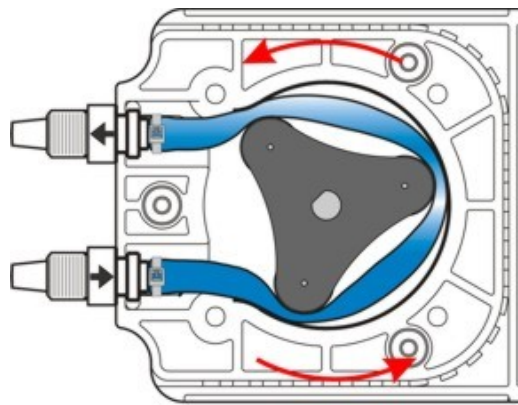

Figure 20: Peristaltic pump

4 Hydraulic cylinders

Hydraulic cylinders – also called linear motors – are used to give a unidirectional force through a unidirectional stroke. A typical cylinder is shown on Figure 21.

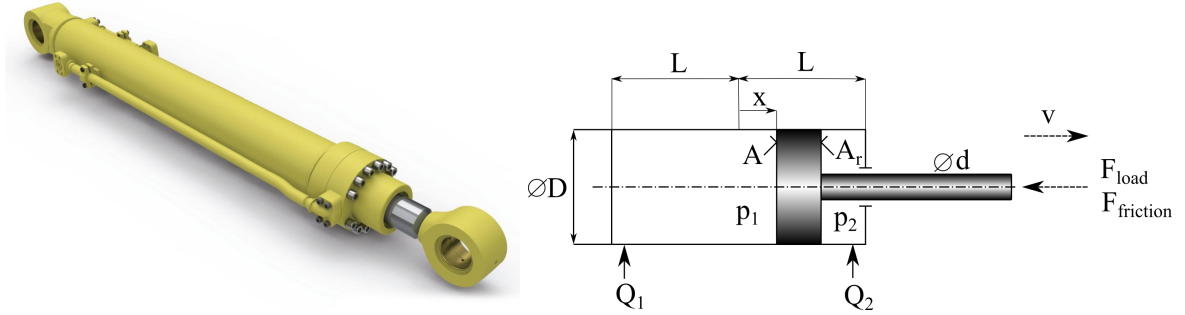

Figure 21: Hydraulic cylinder.

The friction force is cumbersome to measure, thus manufacturers usually provide *mechanical efficiency*, that is

$$\eta_m = \frac{F_{load}}{F_{load} + F_{friction}} \quad (24)$$

The surface ration φ is defined as

$$\varphi = \frac{A}{A_{r(ing)}} = \frac{D^2\pi/4}{(D^2 - d^2)\pi/4} \quad (25)$$

The typical values of diameter ratio are e.g. 1.25, 1.4, 1.6 or 2. The (static) force equilibrium gives

$$p_1A - p_2A_r - F_{load} - F_{friction} = 0, \quad (26)$$

which, upon using (25) and (26) gives

$$A \left(p_1 - \frac{p_2}{\varphi} \right) - \frac{F_{load}}{\eta_m} = 0 \quad (27)$$

This equation is used for the sizing a hydraulic cylinder. The flow rate required to reach a prescribed v piston velocity is

$$Q = Q_{th}\eta_v = \begin{cases} Av\eta_v & \text{if } v > 0 \text{ and} \\ A_rv\eta_v & \text{if } v < 0. \end{cases} \quad (28)$$

5 Pulsation dampener

A pulsation dampener is an accumulator with a set pre-charge that absorbs system shocks while minimizing pulsations, pipe vibration, water hammering and pressure fluctuations. By minimizing pulsation in the system components like regulators, solenoids, sensors, etc., pumps will see decreased wear and have longer life. Pulsation dampeners are tied directly onto the discharge manifold or plumbed immediately downstream of the pump.

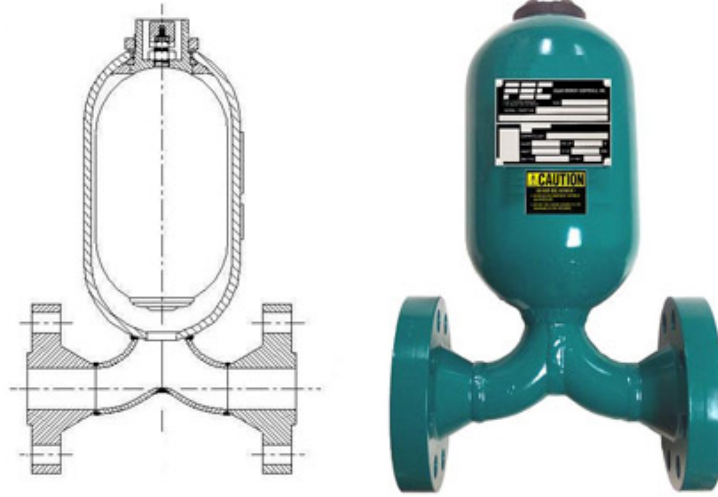

Figure 22: Pulsation dampener.

The most important parameter of the pressure vessel is its nominal volume V_0 , which we shall be able to size. The input parameters of the sizing are

- the average system pressure p_{sys} ,
- the maximum allowed pulsation factor δ_{max} (see Section 18) which we wish to allow
- the size of the pump, i.e. V_{stroke} (i.e. the geometric displacement) and
- the ratio of the pre-charge and system pressure (see next section).

We need a sizing procedure, with which starting from the above data, we can work out the necessary V_0 nominal pressure vessel volume that reduces the pressure pulsation beneath δ_{max} . When adding a pressure vessel to a particular system, we

- mount the vessel to the system but do not open them together, see inset (a) in Figure 23,
- while the valve is still closed, we pre-charge the gas to a prescribed $p_{pc} < p_{sys}$ pressure, see inset (b) in Figure 23 and
- finally, we open the valve. As $p_{pc} < p_{sys}$, liquid will entrain into the vessel and compress the gas.

The highly unsteady flow rate arriving from the pump is compensated by the flow into or out of the pressure vessel: as it can be seen in Figure 24, if the pump flow rate is higher than the system demand (which is constant Q_{mean}), we have inflow into the pressure vessel, i.e. the liquid volume increases, hence the gas volume decreases and the gas pressure also increases. However, in the second half of the period, when the pump flow is zero, this extra liquid volume covers the system flow rate, i.e. we have outflow from the pressure vessel towards the system, the gas expands and its pressure decreases.

We develop now a sizing rule for the dampener by analysing a single-acting pump. The instantaneous and

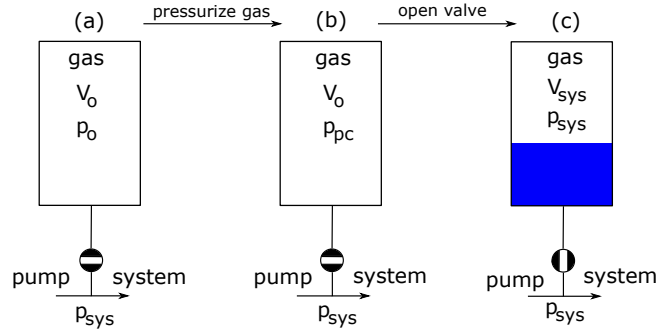

Figure 23: Mounting the pressure vessel.

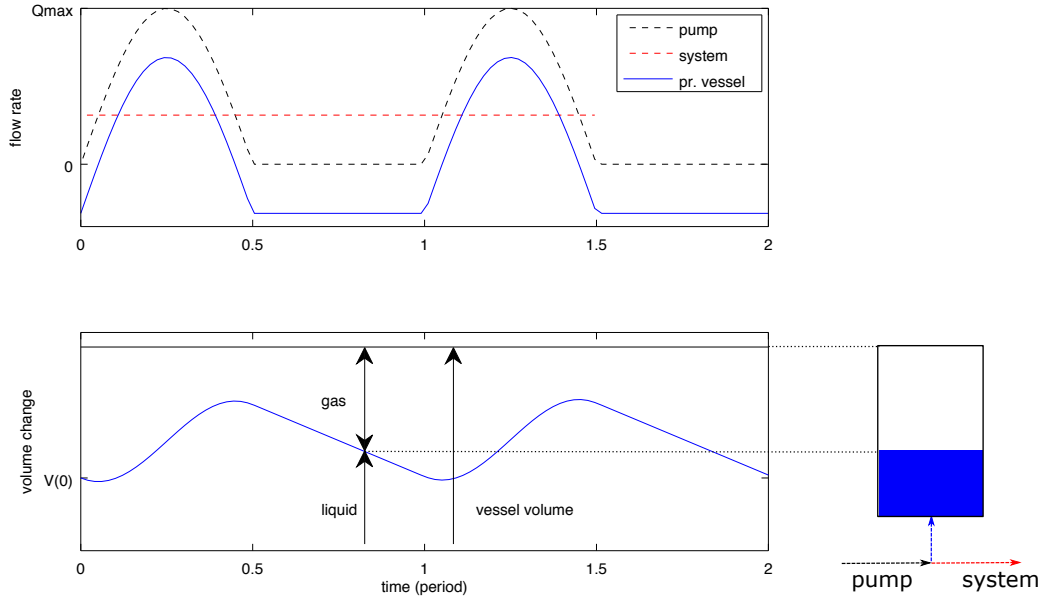

Figure 24: Flow rate and volume change in a pressure vessel.

mean flow rate for a single piston pump is

$$Q(t) = Q_{max} \sin(\omega t) \quad \text{and} \quad Q_{mean} = \frac{Q_{max}}{\pi}, \quad \text{where} \quad Q_{max} = \pi A_D s n. \quad (29)$$

For multi-piston pumps, the pump flow rate is $Q_p(t) = \sum_{i=1}^N Q_i(t)$, where Q_i is the flow rate of the i th piston, i.e. (29) shifted with an angle of $\phi_i = (i - 1) 2\pi/N$, N being the number of pistons. The average flow rate of the pump is $Q_{p,mean} = N Q_{mean}$.

The flow rate entering the damper is (see upper part of Figure 24)

$$Q_d(t) = Q_p(t) - Q_{p,mean}, \quad (30)$$

while the volume of fluid entering (or leaving) the damper up to time t is ((see lower part of Figure 24)

$$V_d(t) = V(0) + \int_0^t Q_d(\tau) d\tau. \quad (31)$$

In the case of a single piston, we have

$$Q_d(t) = \begin{cases} Q_{max} \left(\sin(\omega t) - \frac{1}{\pi} \right) & \text{if } 0 \leq t \leq \frac{T}{2} \\ -Q_{max}/\pi & \text{if } \frac{T}{2} \leq t \leq T \end{cases} \quad \text{and} \quad (32)$$

$$V_d(t) = \begin{cases} Q_{max} \left(-\frac{1}{\omega} (\cos(\omega t) - 1) - \frac{t}{\pi} \right) & \text{if } 0 \leq t \leq \frac{T}{2} \\ -tQ_{max}/\pi & \text{if } \frac{T}{2} \leq t \leq T. \end{cases} \quad (33)$$

The above expression for V_d also ensures that $V_d(0) = 0$. Maximum and minimum volume occurs at $Q_p = 0$, i.e.

$$\omega t_{min} = \arcsin \frac{1}{\pi} \quad \rightarrow \quad t_{min} = \frac{0.3239}{2\pi} T = 0.0516 T. \quad (34)$$

$$\omega t_{max} = \pi - \arcsin \frac{1}{\pi} \quad \rightarrow \quad t_{max} = \frac{\pi - 0.3239}{2\pi} T = 0.4484 T. \quad (35)$$

The corresponding volumes are

$$V_{min} = -0.0081 Q_{max} T = \underbrace{-0.0081\pi}_{-0.0256} \underbrace{Q_{mean} T}_{V_{stroke}} \quad \text{and} \quad V_{min} = 0.1673 Q_{max} T = 0.5256 V_{stroke}, \quad (36)$$

hence the total volume variation on the damper is

$$\Delta V = V_{max} - V_{min} = 0.55 V_{stroke}. \quad (37)$$

We have seen that in the case of a single-acting piston pump, the volume change in the pressure vessel – and hence the volume change of the gas above the liquid – is $0.55 V_{stroke}$. Without the boring details, similar calculation for a double-acting piston gives

$$t_{min} = 0.1098 T, \quad t_{max} = 0.3902 T \quad \text{and} \quad \Delta V = V_{max} - V_{min} = 0.2105 V_{stroke} \quad (38)$$

For pumps with 3 or 4 pistons, the analytical derivation is even more cumbersome, instead, one can simply plot the graphs and evaluate the results numerically giving $\Delta V = 0.009 V_{stroke}$ for triplex and $\Delta V = 0.044 V_{stroke}$ for four-cylinder pumps, see Figure 25. The volume change is given in the percentage of the stroke:

$$\Delta V = \nu V_{stroke}, \quad \text{with} \quad \begin{cases} N = & 1 & 2 & 3 & 4 \\ \nu = & 0.55 & 0.21 & 0.009 & 0.044 \end{cases} \quad (39)$$

Now let us find the pressure pulsation of the *gas* due to the fluid volume change ΔV . We start off by defining the pre-charge pressure p_{pc} (e.g. 80% of system pressure), at which the gas volume is V_0 (i.e. the nominal volume of the damper) and the required level of damping $\delta = (p_{max} - p_{min})/p_{sys}$. The corresponding *gas* volumes will be V_{max} (corresponding to p_{min}) and V_{min} (corresponding to p_{max}). At system pressure, the the gas volume is V_{sys} , see Figure 23 again. We also have $V_{max}^g = V_{min}^g + \Delta V$.

Notice that if the process is isotherm (which is usually true in real-life cases), we have)

$$\delta = \frac{p_{max} - p_{min}}{p_{sys}} = \frac{\Delta p}{p_{sys}} \approx \frac{\Delta V}{V_{sys}} = \frac{\nu V_{stroke}}{V_{sys}}. \quad (40)$$

(We assumed that $\frac{p_{sys}}{V_{sys}} \approx \frac{p_{sys} + \Delta p/2}{V_{sys} - \Delta V/2}$.) We still need an expression for V_{sys} , which, upon making use of Figure 24 and assuming isotherm process is

$$p_{pc} V_0 = p_{sys} V_{sys} \quad \rightarrow \quad V_{sys} = \frac{p_{pc}}{p_{sys}} V_0, \quad (41)$$

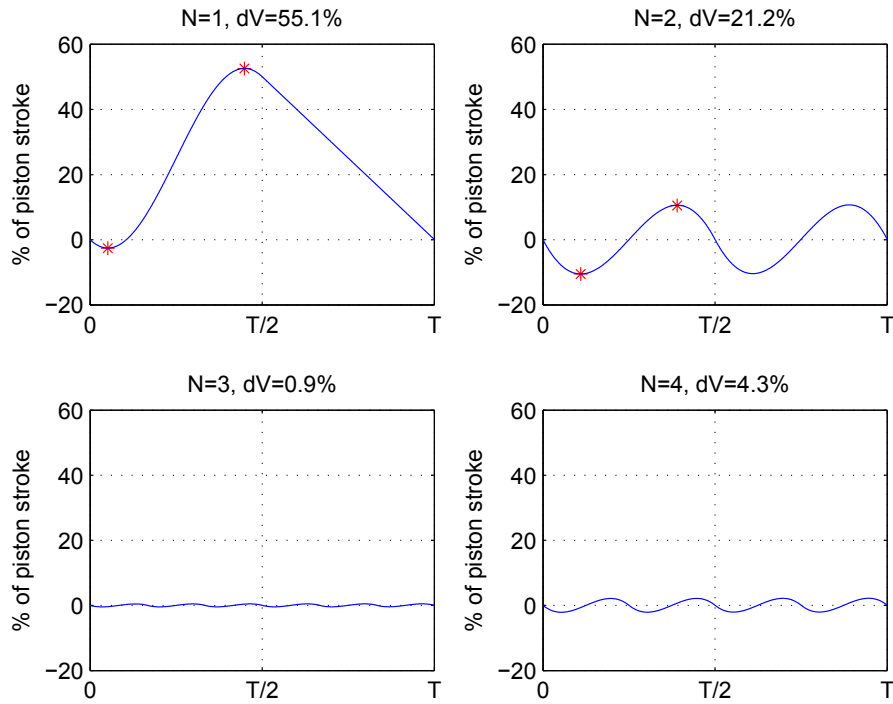

Figure 25: Volume change in the pressure dampener for different number of pistons.

hence the required dampener volume is

$$V_0 = \frac{\nu V_{stroke}}{\frac{p_{pc}}{p_{sys}} \delta_{max}}. \quad (42)$$

Example. We have a duplex pump ($N = 2$, $\nu = 0.2105$) with $s = 60\text{mm}$ stroke and $D = 63\text{mm}$ diameter. What size of pulsation dampener should we use if we want to keep the pulsation level beneath $\delta_{max} = 5\%$?

- The stroke volume is $V_{stroke} = \frac{D^2 \pi}{4} s = 0.187$ liter
- The precharge pressure is set to 80% of system pressure: $p_{pc}/p_{sys} = 0.8$
- The nominal dampener volume is $V_0 = \frac{0.2105 \times 0.187}{0.8 \times 0.05} = 0.984 \approx 1$ liter.

6 Pressure relief valves (PRV)

As we have seen, the flow rate of a PDP is hardly affected by the system pressure, hence even if the flow rate need of the system is zero, the pump will convey the flow rate into the system. In such cases, the system pressure quickly rises and, if not vented, some component will break leading to a failure in the system. To prevent such problems, pressure relief valve (PRV) must be mounted **as close to the pump as possible**. Even for circuits in which the pump may have an integral maximum pressure control, an independent relief valve provides additional redundancy.

These devices open above a *set pressure* allowing controlled backflow to the the tank. If the system pressure is below the st pressure, the PRV remains closed and does not affect the system behaviour.

6.1 Direct spring loaded hydraulic PRV

Direct spring loaded pressure relief valves (DSLPRV) are simple and robust. The spool is balanced by a spring (upper side) and the pressure force (lower side). Note that the flow-through area varies with the valve lift (see Figures 26a and 27).

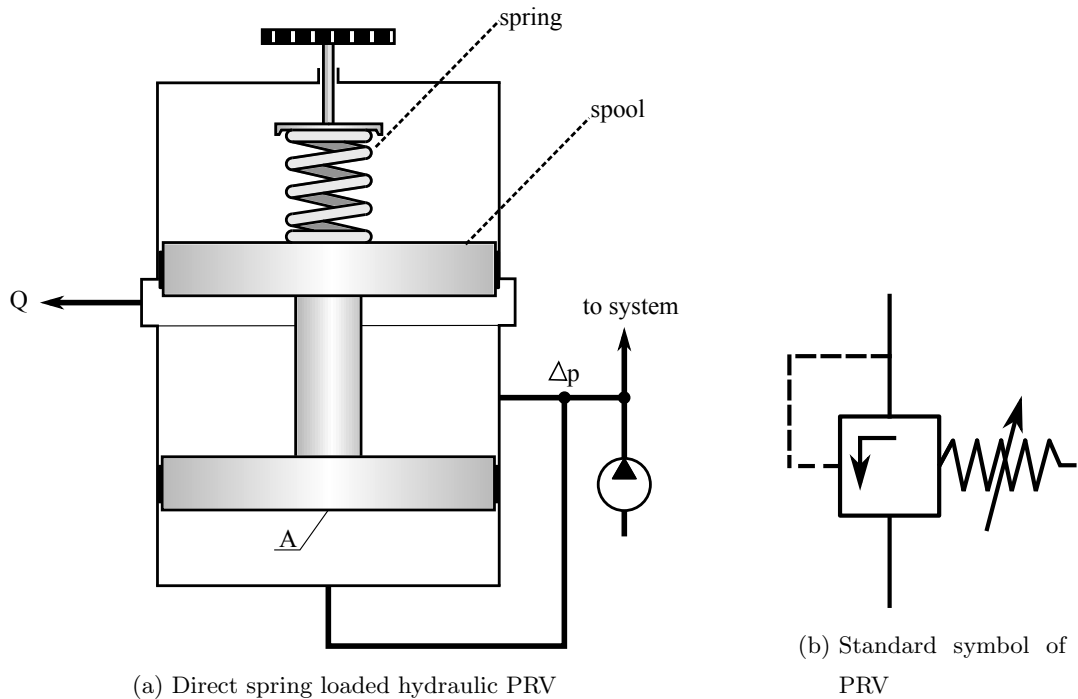

Figure 27 depicts the typical dimensions of a PRV, i.e. the spool outer diameter is D , the spool lift is x , hence the flow-through area is $D\pi x$ as long as $x < x_{max}$, where x_{max} the maximum axial dimensions flow-through area.

Figure 28 shows a typical PRV used in the gas industry. Notice that here the spool is replaced by a simple disc-shaped poppet (which can also be a cone or a ball), which allows leakage-free closing unlike the spool type, where there will always be some leakage.

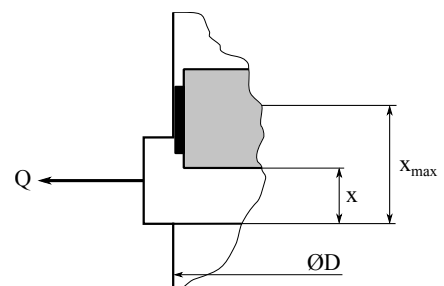

Figure 27: Detail of a direct spring loaded hydraulic PRV

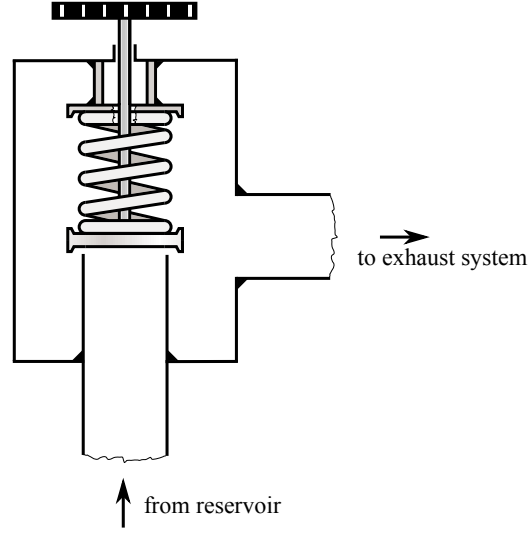

Figure 28: PRV used in natural gas industry

In both cases, the force balance of the spool reads $s(x + x_0) = A\Delta p$. The *set pressure*, at which the valve opens is given by $p_{set} = \frac{sx_0}{A}$. In general, the flow rate is $Q = C_d A_{ft} \sqrt{2\Delta p/\rho}$. However, it should be noted that the flow-through area varies with the valve lift:

$$Q(\Delta p) = \begin{cases} 0 & \text{for } x < 0 \\ C_d A_{ft}(x) \sqrt{\frac{2}{\rho} \Delta p} = C_d D \pi \underbrace{\left(\frac{A\Delta p}{s} - x_0 \right)}_x \sqrt{\frac{2}{\rho} \Delta p} & \text{for } 0 < x < x_{\max} \\ C_d D \pi x_{\max} \sqrt{\frac{2}{\rho} \Delta p} & \text{for } x > x_{\max} \end{cases} \quad (43)$$

Note that in the middle range, we have

$$Q(\Delta p) = C_d D \pi \frac{A}{s} \sqrt{\frac{2}{\rho}} \left(\Delta p - \frac{x_0 s}{A} \right) \sqrt{\Delta p} \propto (\Delta p - p_{set}) \sqrt{\Delta p}, \quad (44)$$

that is, it is zero if $\Delta p = 0$ and $\Delta p = p_{set}$. Moreover, for $0 \leq \Delta p \leq p_{set}$ this function is negative, for $\Delta p > p_{set}$, the flow rate is proportional to $\Delta p^{3/2}$. The actual plot is shown in Figure 29b.

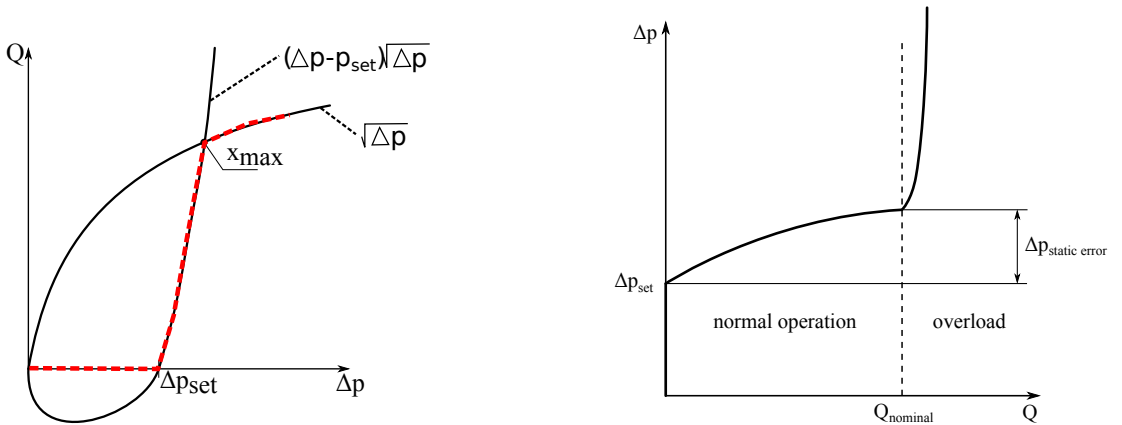

(a) $Q(\Delta p)$ curve of a direct spring loaded hydraulic PRV

(b) Inverse $Q(\Delta p)$ curve of a direct spring loaded hydraulic PRV

The valve body (spool), together with the spring forms a 1 DoF oscillatory system, which is usually poorly damped. (Moreover, in some safety-critical applications, such as safety PRVs in oil industry it is strictly forbidden to add any artificial damping.) Hence, if the pressure rise rate is quick, the valve will open suddenly and perform a usual damped oscillation with some 'overshoot', see Figure 30.

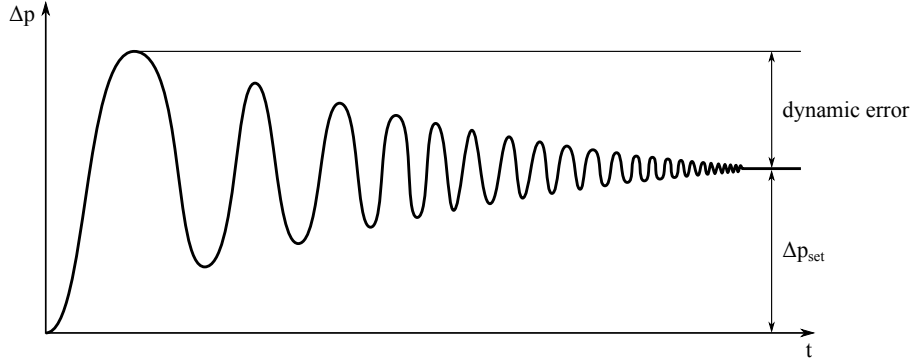

Figure 30: Dynamic error of a direct spring loaded hydraulic PRV

The excess pressure Δp_{dyn} due to the valve body dynamics can be as high as 2...3 times the set pressure Δp_{set} .

6.2 Pilot operated pressure relief valve

For large PRVs (large $Q_{nominal}$), not only the static error increases but also, as the pressure level increases the spring becomes larger, leading to large, heavy valves which are cumbersome to install, maintain or replace. In such cases we replace the main spring by a so-called *pilot*, which is a small (master) valve driving the main (slave) valve, as shown in Figure 31.

The opening pressure is set by the upper main spring and by the pilot valve, which is typically much smaller than the main valve. The spring above the main spool valve is soft and is used only to ensure the return of the main valve into its lower position. Once the system pressure reaches the set pressure, the poppet valve opens and, although the flow through it is small, due to the fixed orifice there will be a Δp pressure drop through it, which results in a pressure imbalance above (where the pressure is $p_{sys} - \Delta p$) and below (where the pressure is still p_{sys}) of the main valve. The pressure difference will move the main spool upwards, opening the main flow-through area.

6.3 Sizing of a pressure relief valves, hydraulic aggregate

As the overpressure protection is essential in the case of hydraulic system pumps and PRVs are often built (and sold) together (with some additional elements, such as tank, filter, etc.) as hydraulic power units or hydraulic aggregates, see Figure 32. If the system pressure is beneath the PRV set pressure ($p_{sys} < p_{set}$), the PRV flow rate is zero and the system is directly fed by the pump, i.e. $Q_{system} = Q_{pump}$ (and $Q_{valve} = 0$). However, if the system pressure exceeds the set pressure, a portion of the pump flow rate will be vented by the valve, i.e.

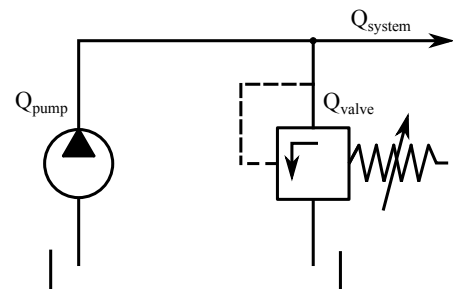

Figure 32: Hydraulic aggregate

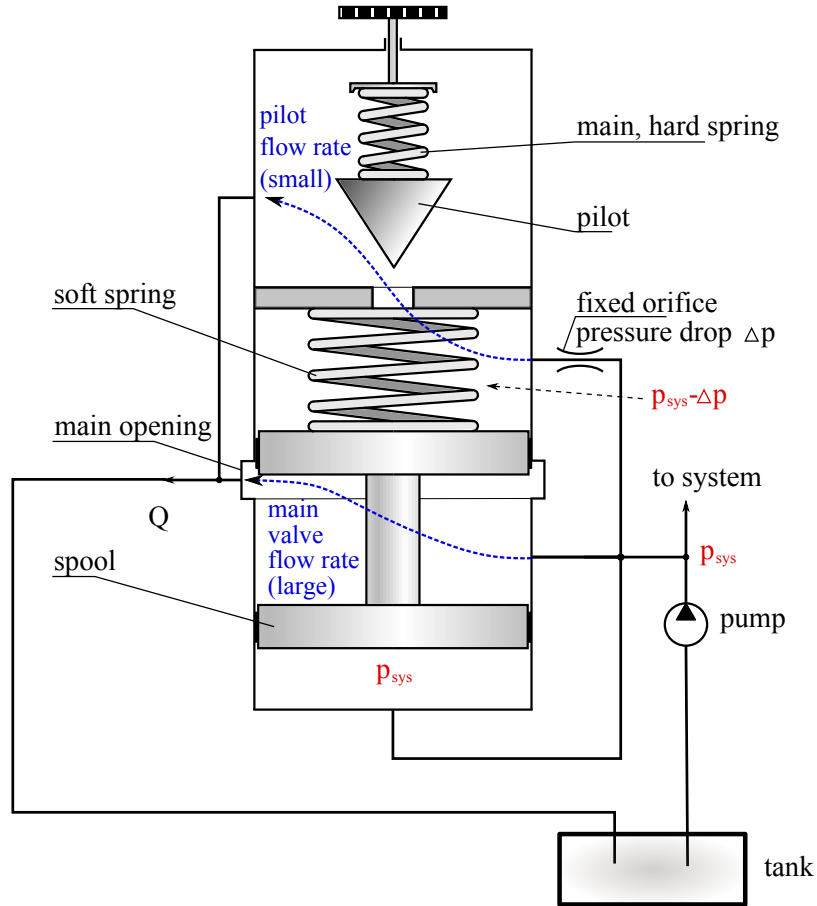
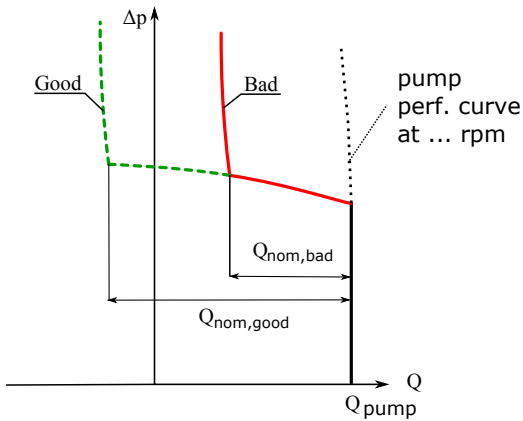

Figure 31: Pilot operated PRV

$Q_{system} = Q_{pump} - Q_{valve}$. We must keep in mind that the system flow rate of the system might vary, for example, because we feed a hydraulic cylinder whose velocity varies. If the system flow rate becomes zero (e.g. because the cylinder stops), we have $Q_{PRV} = Q_{pump}$, i.e. the PRV has to be able to vent the maximum pump flow rate in the normal operation range:



$$Q_{pump,max} < Q_{nom}, \tag{45}$$

where Q_{nom} is the PRV's nominal flow rate (available in the catalogue). It is clear that if the above requirement is not fulfilled, the PRV will not be able to protect the system from excess pressure if the flow rate requirement decreases to zero.

Figure 33: Selection of PRV.

7 Sizing of simple hydraulic systems

We are now in the position of designing simple hydraulic systems.

7.1 Aggregate with hydraulic motor

The sketch of the system is shown in Figure 34.

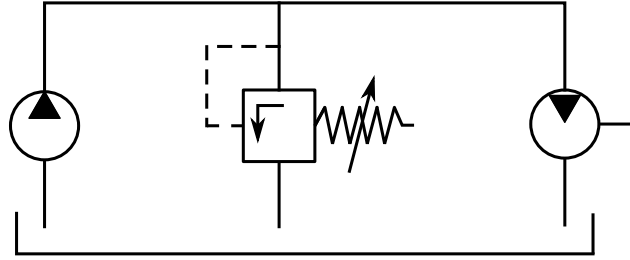

Figure 34: Hydraulic aggregate with motor

The input data are the required hydraulic motor torque M_{motor} and revolution number n_{motor} . We are searching for the pump and motor sizes $V_{g,\text{pump}}$, $V_{g,\text{motor}}$ and the PRV set pressure p_{set} .

- Let us assume that we are given the following requirements: $M_{\text{motor}} = 100 \text{ Nm}$, $n_{\text{motor}} = 1500 \text{ rpm}$
- We choose the system pressure to be $\Delta p = 280 \text{ bar}$.
- First, we need to choose the motor. We have:

$$\underbrace{V_g n \Delta p}_{P_{in}} \eta_{hm} = \underbrace{M 2\pi n}_{P_{out}} \rightarrow V_{g,\text{motor}} = \frac{2\pi M}{\Delta p \eta_{hm}} = 22.44 \text{ cm}^3. \quad (46)$$

- The closest item in the motor catalogue is $V_g = 23.5 \text{ cm}^3$, which gives: $M_{\text{motor}} = \frac{\Delta p V_g}{2\pi} = 104.7 \text{ Nm}$ and $Q_{\text{motor}} = n_{\text{motor}} V_g = 1500 \text{ rpm} \times 23.5 \text{ cm}^3 = 35.25 \text{ liter/min}$.
- The pressure relief valve set pressure is set to approx. 10% above the system pressure, i.e. 308 bar.
- Next step is the pump selection: $V_{g,\text{pump}} = Q/n_{\text{pump}} = \frac{35.25 \text{ liter/min}}{3000 \text{ rpm}} = 11.75 \text{ cm}^3$
- With this pump, the required torque: $\Delta p V_g / (2\pi) = 52.4 \text{ Nm}$

7.2 System with cylinder

For a given objective, usually we know: F , v

To accomplish this objective we have to determinate: $V_{g,\text{pump}}$, p_{set} , $\frac{D}{d}$, control type.

7.2.0.1 Piston control valve From catalogue: $V_{g,\text{pump}}$, $V_{g,\text{motor}}$, $\frac{D}{d}$

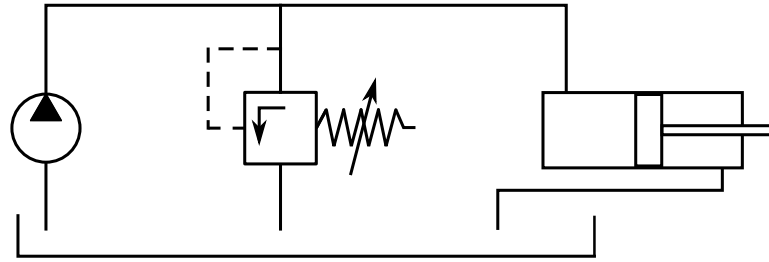

Figure 35: Hydraulic aggregate with cylinder

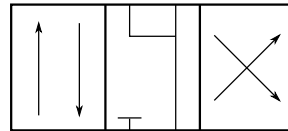

Figure 36: Symbol of the piston control valve

7.2.1 Example for a system with cylinder

$M_{\text{motor}} = 100 \text{ Nm}$, $n_{\text{motor}} = 1500 \text{ rpm}$

$$nV_g \Delta p = M2\pi n \tag{47}$$

$$\Delta p = \frac{M2\pi n}{nV_g} = \frac{2\pi M}{V_g} = \frac{2\pi 100}{28.5 \times 10^{-6}} = 220 \text{ bar} \tag{48}$$

$$Q = V_g n_{\text{motor}} = 28.5 \times 1.5 = 42.75 \text{ l/min} \tag{49}$$

Pick size 28. The aggregate should provide this flow rate at the Δp pressure.

7.2.1.1 Pump Driving motor speed: $n_{\text{pump}} = 3000 \text{ rpm}$

$$Q_{\text{pump}} = n_{\text{pump}} V_{g,\text{pump}} \rightarrow V_{g,\text{pump}} = \frac{Q_{\text{pump}}}{n_{\text{pump}}} = \frac{28.5 \text{ l/min}}{3000 \text{ rpm}} = 14.25 \text{ cm}^3 \tag{50}$$

Pick $V_{g,\text{pump}} = 16 \text{ cm}^3$. With the new value:

$$Q_{\text{pump}} = n_{\text{pump}} V_{g,\text{pump}} = 3000 \text{ rpm} \times 16 \text{ cm}^3 = 48 \text{ l/min} \tag{51}$$

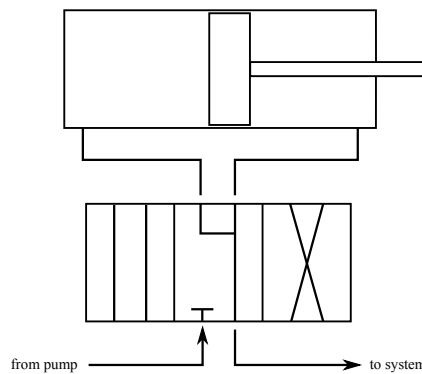

Figure 37: Piston control valve with cylinder

7.2.1.2 Set pressure of the PRV 120 % of the highest expected system pressure.

$$p_{\text{set}} := 1.2 \times 220 = 264 \text{ bar} \quad (52)$$

$Q_{\text{nom,PRV}} > 42.81/\text{min}$ (capacity of PRV).

7.3 Control techniques

- Throttle valve in parallel connection
- Throttle valve in series connection
- Frequency converter
- Special pump: variable displacement motor, variable V_g
- Motor speed (n) changing

7.3.1 Throttle valve in parallel connection

In this setup the throttle valve is connected parallel to the pump and motor, as shown on Figure 38. The pump produces more flow rate, than the hydraulic motor need, so the unnecessary flow rate flows through the adjustable throttle valve. In normal operation the PRV is closed, so no flow goes through it, it has only safety role.

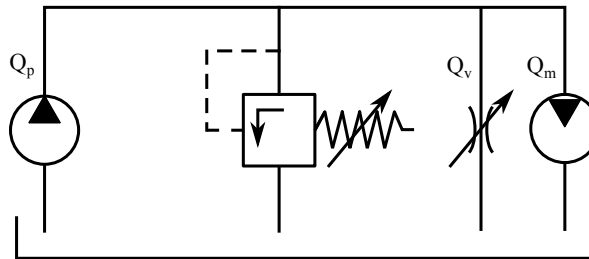

Figure 38: System with throttle valve in parallel connection

The Δp is the same for every element in this case, the pressure is the same in the whole "upper" line.

7.3.1.1 Example We have a situation when we need to operate a hydromotor, which produces $M_m = 120 \text{ Nm}$ torque and $n_m = 1500 \text{ rpm}$. The used hydraulic elements' pressure limit is 400 bar and we have an electric motor driving the pump with $n_p = 3000 \text{ rpm}$. Efficiencies: $\eta_{vol} = 85\%$, $\eta_{hm} = 90\%$ for both pump and motor. The manufactured motors and pumps has displacement $V_g = 20, 25, 30, 35, 40, 45, 50, 55, 60, 65, 70 \text{ cm}^3$. The objective is to find the hydraulic elements and calculate the efficiency of the system.

- Choose the system's working pressure to 300 bar!
- Choose a motor:

$$\underbrace{\eta_{hm} \frac{n_m V_g}{\underbrace{\eta_{vol}}_Q}}_{P_{in}} \Delta p = \underbrace{M_m 2\pi n_m}_{P_{useful}} \rightarrow V_g = \frac{2\pi M_m \eta_{vol}}{\Delta p \eta_{hm}} = \frac{2\pi 120}{300 \times 10^5} \frac{0.85}{0.9} = 23.74 \text{ cm}^3.$$

So we choose the motor with $V_g = 25\text{cm}^3$ ($V_g = 20\text{cm}^3$ is also usable). The required pressure difference:

$$\Delta p = \frac{M2\pi}{V_g} \frac{\eta_{vol}}{\eta_{hm}} = \frac{2\pi 120}{25 \times 10^{-6}} \frac{0.85}{0.9} = 284.8 \text{ bar} \quad (53)$$

And the required flow rate of the motor:

$$Q_m = \frac{nV_g}{\eta_{vol}} = \frac{1500/\text{min} \times 25 \text{ cm}^3}{0.85} = 44.12 \frac{\text{liter}}{\text{min}} \quad (54)$$

- Choose a pump:

$$Q_{pump} = n_{pump} V_g \eta_{vol} \rightarrow V_g = \frac{44.12 \text{ liter}/\text{min}}{3000/\text{min} \times 0.85} = 17.3 \text{ cm}^3. \quad (55)$$

So we choose the pump with $V_g = 20 \text{ cm}^3$ displacement (smaller is not appropriate, because it can't produce enough flow rate).

The produced flow rate:

$$Q_{pump} = nV_g\eta_{vol} = 3000/\text{min} \times 20\text{cm}^3 \times 0.85 = 51 \frac{\text{liter}}{\text{min}} \quad (56)$$

- Set the opening pressure of PRV above the system pressure with 20%: $\Delta p_{PRV} = 1.2 \times 284.8 \text{ bar} = 341.76 \text{ bar} \approx 340 \text{ bar}$
- In case of parallel connected PRV (see Figure 39):

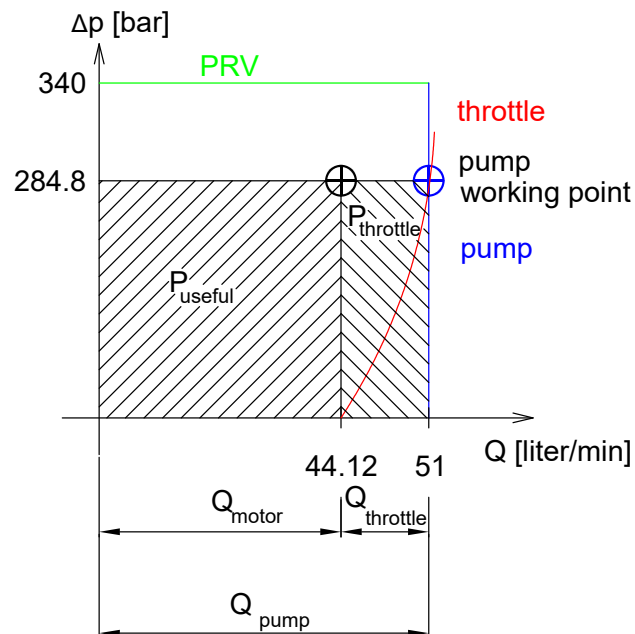

Figure 39: System with throttle valve in parallel connection

$$P_{useful} = 44.12 \text{ liter/min} \times 284.8 \text{ bar} = 20.9 \text{ kW}$$

$$P_{in} = 51 \text{ liter/min} \times 284.8 \text{ bar} = 24.2 \text{ kW}$$

$$P'_{throttle} = (51 - 44.12) \text{ liter/min} \times 284.8 \text{ bar} = 3.2 \text{ kW}$$

$$P'_{PRV} = 0 \text{ kW}$$

$$\eta = 20.9/24.2 = 86.4\%$$

7.3.2 Throttle valve in series connection

In this put the throttle valve between the pump+PRV unit and the motor in series, so the fluid which flows through the motor has to flow through the throttle first. The pressure loss of the throttle is adjusted to the point, where the output pressure (of throttle valve) is the required motor input pressure.

The PRV is opened in normal operation in this setup, the pump produces more flow rate, than the motor uses, so the unused flow rate goes back to the vessel through the PRV.

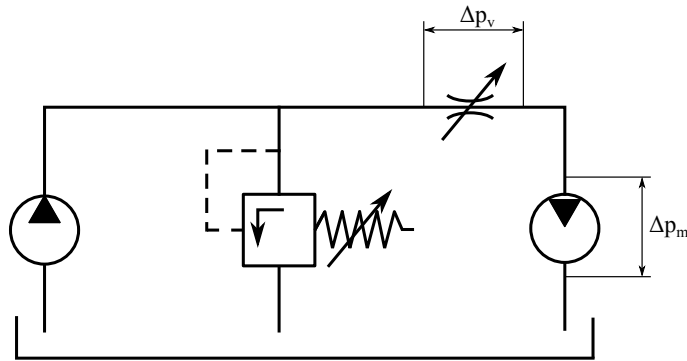

Figure 40: System with throttle valve in series connection

7.3.2.1 Example Take the former example, but now with series connected throttle valve. The first part of the sizing is the same, until we calculate powers. Powers and efficiency in case of series connected throttle:

$$P_{useful} = 44.12 \text{ liter/min} \times 284.8 \text{ bar} = 20.9 \text{ kW}$$

$$P_{in} = 51 \text{ liter/min} \times 340 \text{ bar} = 28.9 \text{ kW}$$

$$P'_{throttle} = 44.12 \text{ liter/min} \times (340 - 284.8) \text{ bar} = 4.1 \text{ kW}$$

$$P'_{PRV} = (51 - 44.12) \text{ liter/min} \times 340 \text{ bar} = 3.9 \text{ kW}$$

$$\eta = 20.9/28.9 = 72.3\%$$

As shown, the parallel connection has better efficiency, so economically it is the better choice.

Note: If we need a hydraulic cylinder instead of motor, then we know the required force F and cylinder rod velocity v . In this case with the area of piston we can calculate the required pressure ($F = A_D \Delta p$), and the required flow rate ($Q = A_D v$). After this steps the remaining part of calculation is the same as presented above.

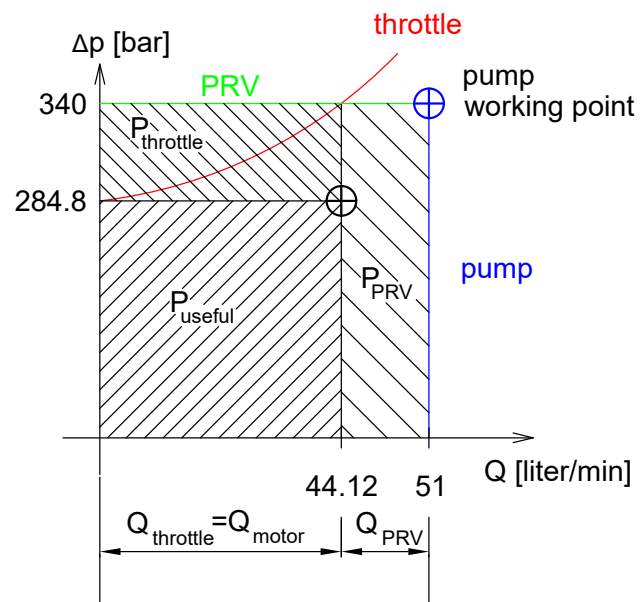

Figure 41: System with throttle valve in series connection

8 Compressors

TODO

9 TODO

- HP: Add cylinders section 4 based on the Hungarian HPH notes, minus the dynamic modeling.
- HP: Add more info on section 7, especially the numerical examples. Use figure from the Hungarian notes.
- HCs: Compressors.